

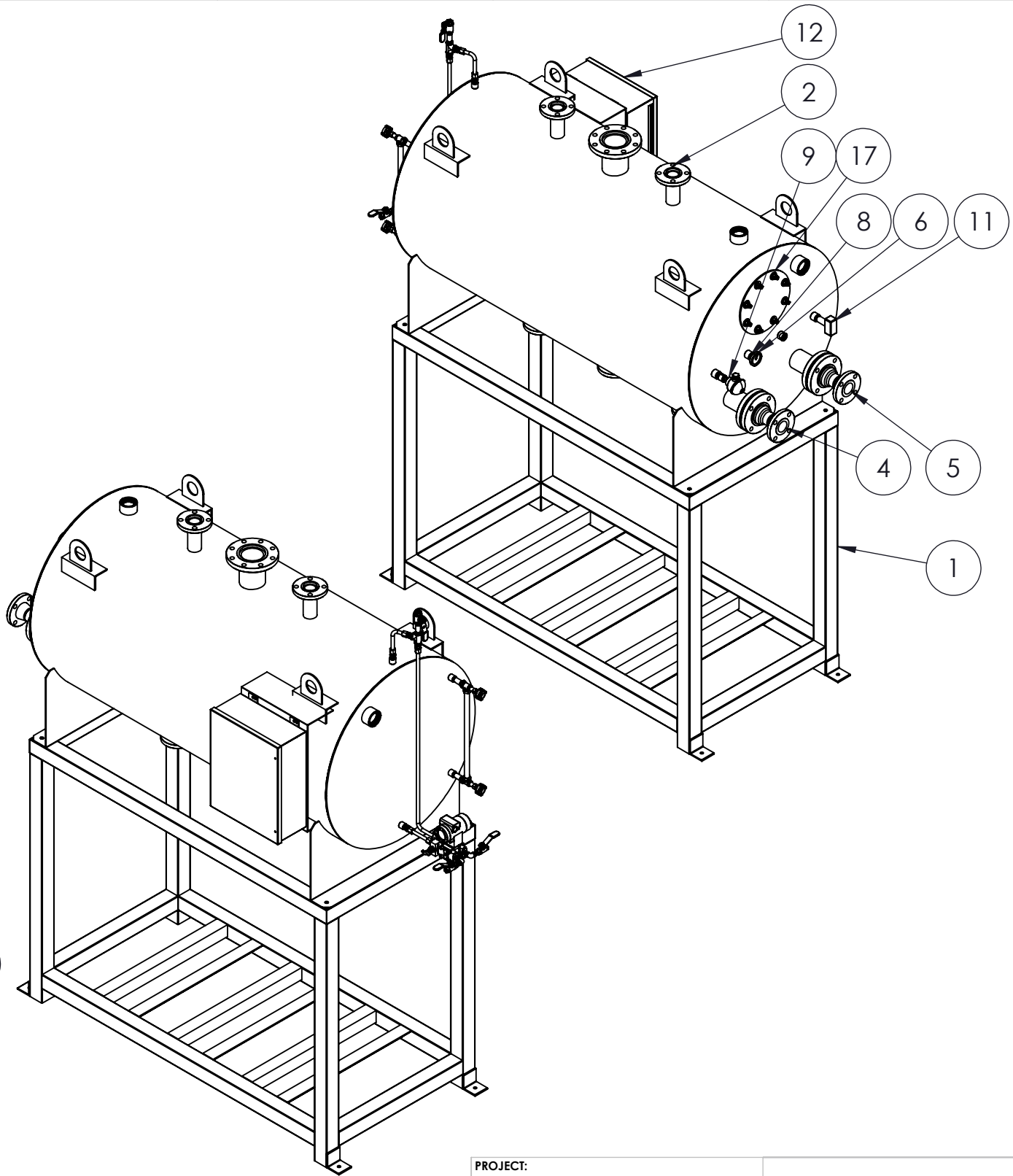

Nozzel Connection Table			
Conn.	Size	Type	Despcriton
N1	Ø 3"	ANSI 150# - STAINLESS STEEL	TANK STEAM SPARGE
N2	Ø 3"	ANSI 150# - STAINLESS STEEL	STEAM SPARGE TUBE INLET
N3	Ø 2"	ANSI 150# - STAINLESS STEEL	TANK CONDENSATE SPARGE
N4	Ø 2"	ANSI 150# - STAINLESS STEEL	CONDENSATE SPARGE TUBE INLET
N5	Ø 2"	ANSI 150# - STAINLESS STEEL	CONDENSATE RETURN
N6	Ø 4"	ANSI 150# - STAINLESS STEEL	VENT
N7	Ø 2"	ANSI 150# - STAINLESS STEEL	CONDENSATE RETURN
N8	Ø 3/4"	NPT - STAINLESS STEEL	RTD
N9	Ø 3/4"	NPT - STAINLESS STEEL	THERMOMETER
N10	Ø 3/4"	NPT - STAINLESS STEEL	OVER FLOW
N11	Ø 3/4"	NPT - STAINLESS STEEL	CHEMICAL INJECTION
N12	Ø 3/4"	NPT - STAINLESS STEEL	CONDUCTIVITY SENSOR
N13	Ø 1/2"	NPT - STAINLESS STEEL	DIFFERENTIAL PRESSURE
N14	Ø 1/2"	NPT - STAINLESS STEEL	DIFFERENTIAL PRESSURE
N15	Ø 1"	NPT - STAINLESS STEEL	PUMPS SPILLBACK
N16	Ø 2"	ANSI 150# - STAINLESS STEEL	PUMP SUCTION
N17	Ø 2"	ANSI 150# - STAINLESS STEEL	PUMP SUCTION
N18	Ø 2"	ANSI 150# - STAINLESS STEEL	PUMP SUCTION
N19	Ø 2"	NPT - STAINLESS STEEL	DRAIN
N20	Ø 2"	NPT - STAINLESS STEEL	SPARE
N21	Ø 1/2"	NPT - STAINLESS STEEL	SIGHT GLASS LEVEL
N22	Ø 1/2"	NPT - STAINLESS STEEL	SIGHT GLASS LEVEL
N23	Ø 2"	NPT - STAINLESS STEEL	MAKE UP
N24	Ø 8"	OPENING	INSPECTION

ESTIMATED DRY WEIGHT: - LBS PROPRIETARY AND CONFIDENTIAL	PROJECT: P109 - 300 GAL. FEED TANK	
	CLIENT/CUSTOMER: -	
-	PAGE DESCRIPTION: 300 GAL. FEED TANK	SCALE: 1:50 DWG SIZE: B SHEET: 1 OF 2 DRAWN BY: - DATE: 24/02/2017 APPROVED BY: MARCUS BELLOT DATE: 24/02/2017 DWG NO. 109-C001 REV: 0
	MODEL #: -	
	WORK ORDER #: -	

ITEM NO.	PART NUMBER	DESCRIPTION	QTY.
1	TANK SUPPORT FRAME	CARBON STEEL - SHEET 9	1
2	300 GAL. FEED TANK WITH PIPING AND FITTINGS	CARBON STEEL - SHEET 3	1
3	Ø 3" SPIRAL WOUND GASKET	SS - 150#	2
4	STEAM SPARGE TUBE WELDMENT	STAINLESS STEEL - SHEET 14	1
5	CONDENSATE SPARGE TUBE WELDMENT	STAINLESS STEEL - SHEET 15	1
6	TEMPERATURE GUAGE		1
7	DIFFERENTIAL PRESSURE TRANSMITTER	SIEMENS	1
8	Ø 3/4" X Ø 1/2" NPT STAINLESS STEEL REUCING BUSHING		1
9	Ø 1/2" RTD ASSEMBLY	WIKA	1
10	SIGHT GLASS LEVEL	APOLLO	1
11	Ø 3/4" CONDUCTIVITY SENSOR TDS - DCM400-145U	KLENZOID	1
12	FEED TANK CONTROL PANEL		1
13	Ø 12 " INSPECTION OPENING TANK GASKET		1
14	Ø 1/2" X 1-3/4" LONG HEX BOLT	STAINLESS STEEL	8
15	Ø 1/2" WASHER	STAINLESS STEEL	8
16	Ø 1/2" HEX NUT	STAINLESS STEEL	8
17	FEED TANK INSPECTION OPENING COVER	1/4" STAINLESS STEEL - SHEET 13	1

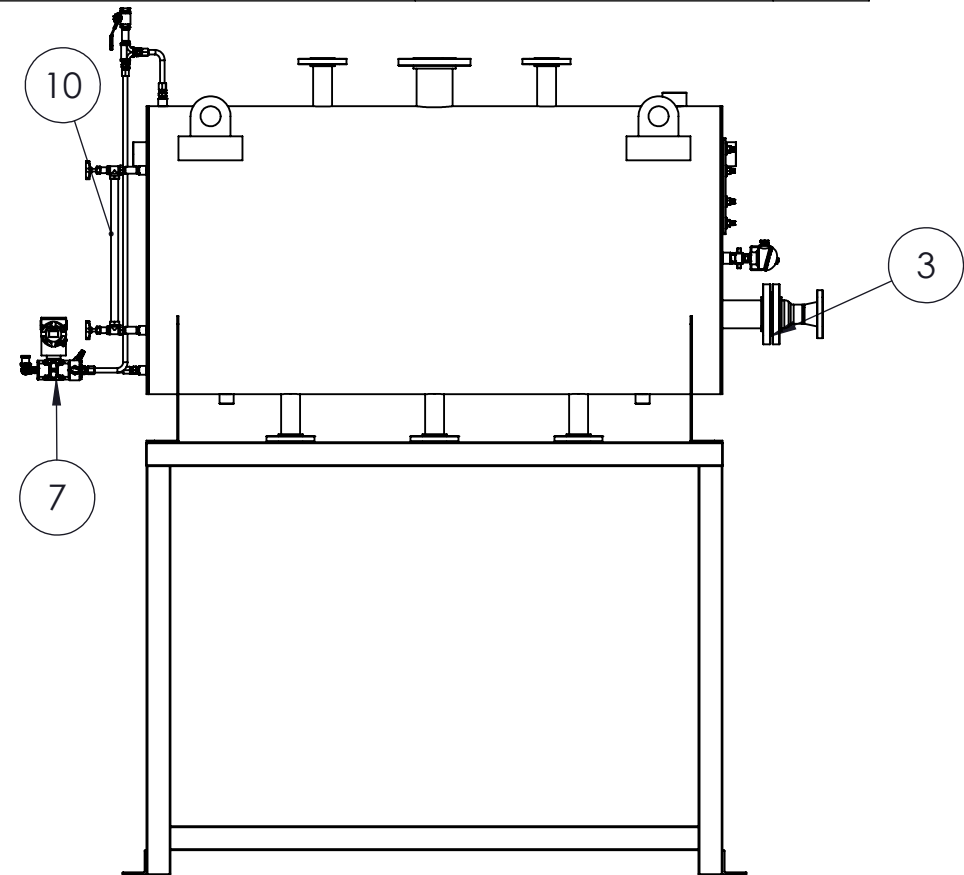

PROJECT: P109 - 300 GAL. FEED TANK	
CLIENT/CUSTOMER: -	
ESTIMATED DRY WEIGHT: - LBS	PAGE DESCRIPTION: 300 GAL. FEED TANK
PROPRIETARY AND CONFIDENTIAL	MODEL #: -
	WORK ORDER #: -
	SCALE: 1:50 DWG SIZE: B SHEET: 2 OF 2
	DRAWN BY: - DATE: 24/02/2017
	APPROVED BY: MARCUS BELLOT DATE: 24/02/2017
	DWG NO. 109-C001 REV: 0