



Molabolt Product Information

May 2017

Molabolt. The Bolt Has Been Reborn

Molabolt works by having the ability to expand once in position, providing a firm and completely reliable hold.



Product Advantages

- Fast and easy to use
- Doesn't require any specialist skill or tools
- Provides a firm, strong grip
- Quality Assured
 Products are manufactured in 8.8 steel, conforming to Grade Specification BSEN 20898/1992. Fully safety tested to UKAS accredited standard ISO 9000 manufacturing standards. Supplied to TS 16949 approved standards.

Product Range

- Peg Anchor Molabolt
- Anti-Vibration Molabolt
- Threaded Bypass Molabolt
- Fire Resistant Molabolt

Peg Anchor Molabolt.

Solving the problem of blind applications in construction



Fast becoming the established alternative to welding when dealing with steelwork fabrication involving blind box sections. Its many advantages include speed of application, ease of use, no special skill, tools or equipment required and the reassurance to know that when correctly fitted the Peg Anchor Molabolt is at least as strong as a standard bolt. It has been used in many high profile developments throughout the UK and now boasts many committed customers.

Installation

1. Locate nut at top of stud
2. Insert into hole, allowing slotted section to pass through hole
3. Strike pin home
4. Torque to ABS recommendations

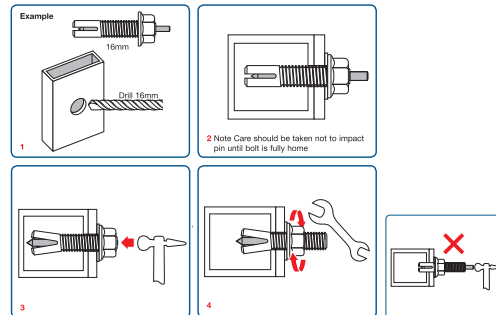

Order No.	Size	Grade	Finish	Clamping Range Max (mm)	Torque (Nm)	Tensile Load* (kN)	Shear Load* (kN)
PA0850	M8X50	8.8	Zinc Plated	34	20	4	14.6
PA1040	M10X40	8.8	Zinc Plated	20	35	6.4	20
PA1050	M10X50	8.8	Zinc Plated	30	35	6.4	20
PA1060	M10X60	8.8	Zinc Plated	40	35	6.4	20
PA1250	M12X50	8.8	Zinc Plated	26	50	9.8	32.6
PA1260	M12X60	8.8	Zinc Plated	36	50	9.8	32.6
PA1275	M12X75	8.8	Zinc Plated	51	50	9.8	32.6
PA1660	M16X60	8.8	Zinc Plated	28	100	15.0	50.2
PA2075	M20X75	8.8	Zinc Plated	35	125	22.0	80.4
PA2475	M24X75	8.8	Zinc Plated	27	175	29.15	147

*SWL figures include a safety factor of 5 for tensile loading and 1.5 for shear loading based on ultimate load results.

Other sizes are available on request

Stainless steel, Dorreltech and Galvanized finish are available

Anti-Vibration Molabolt.

Solving the problems of vibration

The Anti-Vibration Molabolt available from R.S. Johnston, deals unequivocally with the problems and safety issues surrounding bolted connections that are subject to vibration, those with a critical dependency on locking agents or low tolerance to locking torque.

The Anti-Vibration Molabolt can also be used for fitting soft or fragile materials such as aluminum or glass.

This Molabolt can be unlocked, and removed if required.

As with other Molabolts its advantages over any alternatives are speed and ease of application, and no special skill or tools are required.

The Anti-Vibration Molabolt is ideal for those situations where construction and movement come together such as railways, wind turbines and lift shafts.

Other applications include transport and mechanical engineering; in fact anywhere that vibration challenges come to bear the Anti-Vibration Molabolt has a role to play.

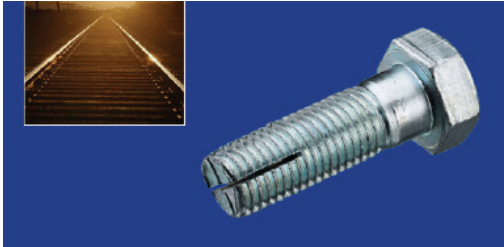

Fast and easy application

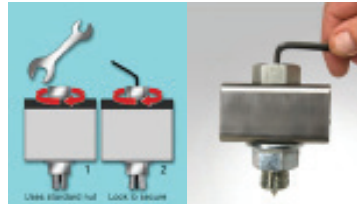

Threaded Bypass Molabolt.

Solving the problem of worn or damaged thread

Eliminates the need to repair or discard expensive components because of thread damage and also reduces downtime and assembly time to a minimum.

Available in two versions for permanent and temporary repair.

For urgent maintenance demands the Threaded Bypass Molabolt also comes in a handy kit form.

The Molabolt benefits of speed and ease of application and no special skills or tools required also apply to the Thread Bypass Molabolt.

Particularly suitable for corrosive environments such as in shipping and dockside equipment.

Also where machine stoppages need to be cut to the minimum. Those involved in automotive engine, chassis and body work restoration also find this Molabolt invaluable.



Fast and easy application

Permanent

Removable

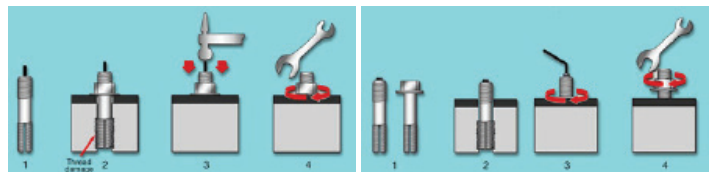

Fire Resistant Molabolt.

Solving the problem maintaining steel structures in intense heat

The Fire Resistant Molabolt was designed especially for concrete filled hollow steel sections to increase the evacuation time in multi-storey constructions under fire conditions.

Corus encouraged Molabolt to develop the Fire Resistant Molabolt following the impact of 9/11 to help deal with the vulnerability of tall steel constructions in intense fires. The Fire Resistant Molabolt uses the Molabolt principle with the addition of a shield to disperse the heat, thereby protecting the Molabolt.



Fast and easy application

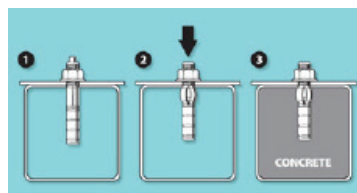

R.S. Johnston

Industrial Fastening Systems

16 Diamond Road, Dromore, Co Down BT25 1PH
 Tel: 02892 699644 Fax: 02892 693498 Email: info@rsjohnston.co.uk