



Bring the fresh in.



Dedicated Outside Air Systems



The inside story on outside air.

On average, we breathe in 3,400 gallons of air each day. Ambient indoor air pollution is a major problem, affecting health and productivity in the workplace. Bringing in fresh, outside air is critical to maintaining indoor air quality.

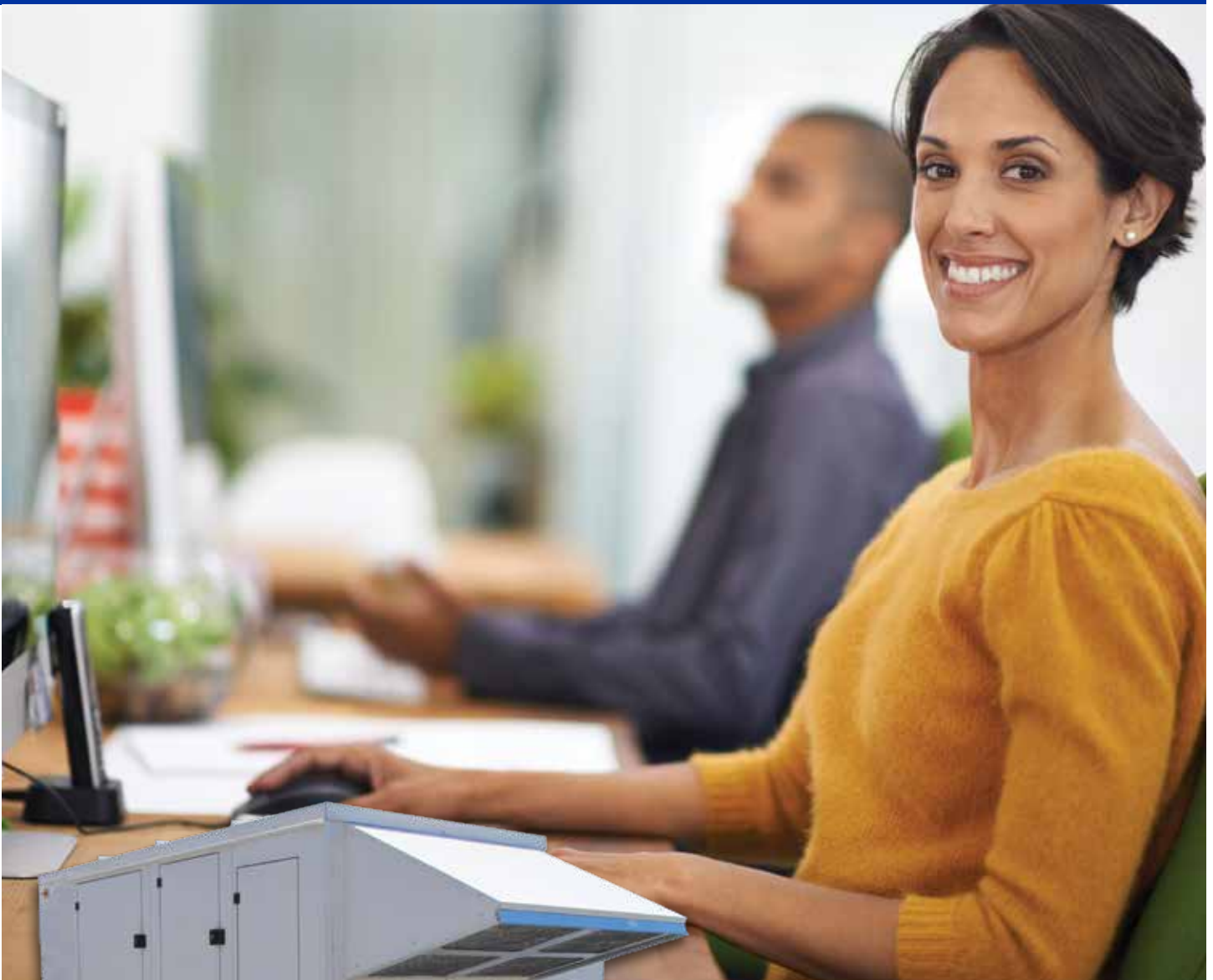

Dedicated Outside Air Systems



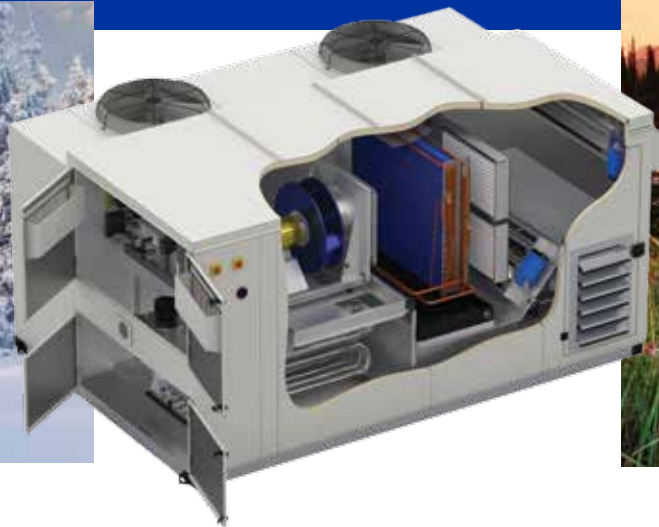
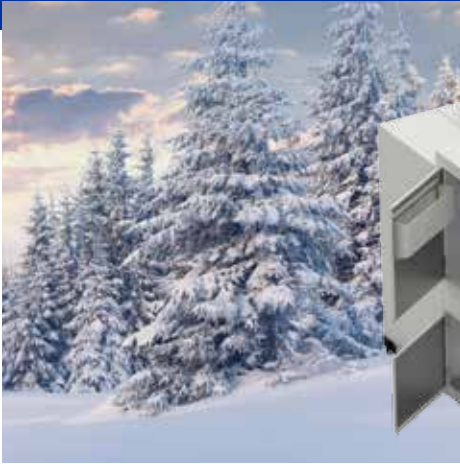

Fresher air. Higher efficiency.

A Dedicated Outside Air System (DOAS) from YORK delivers clean, dehumidified outside air in all weather and climate conditions. New standards for efficiency and high performance green buildings continue to put pressure on designing building systems. With a YORK DOAS, you can meet ASHRAE requirements for fresh air and your requirements for energy efficiency. As standards and guidelines continue to evolve, you have the flexibility to easily adapt.

Count on high efficiency and proven performance in both heating and cooling conditions. Plus, you get the quality performance you expect from YORK equipment, including:

- Energy savings no matter what the season
- Robust construction for reliability and long life
- More factory installed options for easy installation

The right combinations.

The DOAS unit is designed for more combinations of heating and cooling than other units. For northern climates requiring extra heat or southern climates needing more cooling, the DOAS unit can handle it.

Makeup and ventilation air application characteristics

- Up to 100% outside air
- Continuous conditioning of the air
- Extended operational time (up to 24 / 7)
- Precise unit CFM delivery

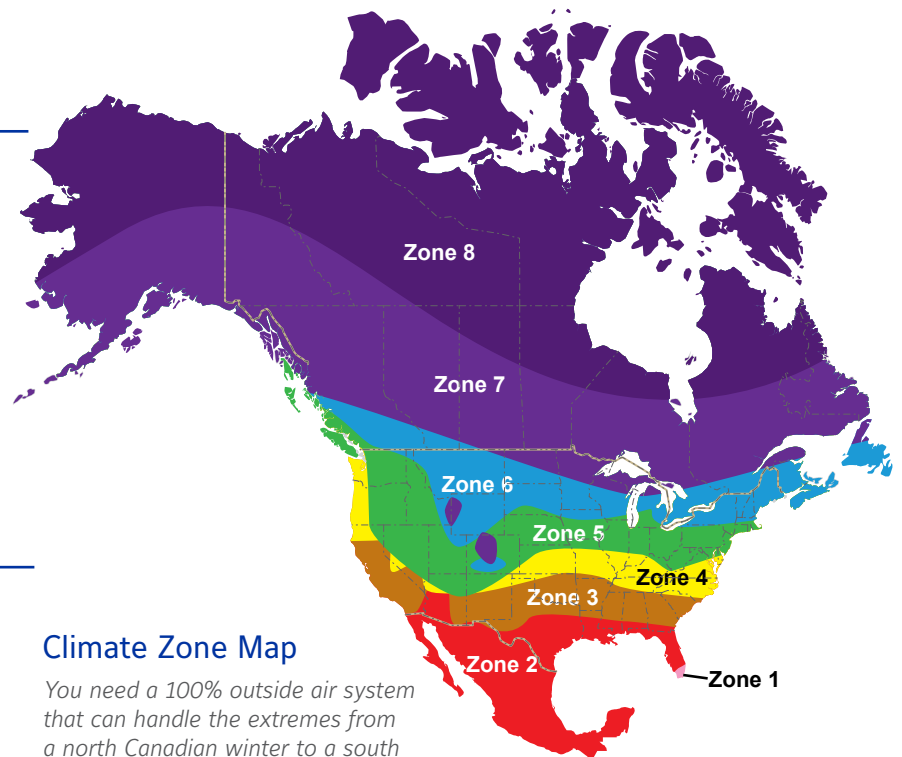

Bring the fresh in.



When the heat is on.

Don't worry about pipes freezing or blowing cold air on a person in extreme weather conditions. The unit's heating system is designed to handle extreme weather conditions as well as spring time light-load days. The heating system can provide 100°F rise with turn down as low as 10% with gas control.

- 5:1 or 10:1 gas modulation
- 92% & 80% gas heating efficiency
- Constant thermal efficiency gas heating during modulation
- 409 stainless steel heat exchangers
- SCR electric heat modulation
- Safeties and alarms
- Condensate neutralizer
- High capacity heat

Performance under any conditions.

The YORK DOAS features an independent reheat system. This allows stable, predictable year-round performance. Its digital capacity control reliably maintains consistent 52° – 55° F discharge air temperature during spring, summer and fall seasons.

Cool thinking.

Allowing large volumes of hot, untreated air to enter a conditioned space creates uncomfortable conditions and loss of environmental control. Using 100% outside air means treating the air in all conditions. From 55°F through 115°F, the mechanical cooling system operates to properly condition the air, meeting the needs of a variety of applications.

- Energy efficient compressors
- 10%-100% capacity modulation
- ECM condenser fans
- Low ambient operation
- Corrosion-proof, double sloped drain pan
- Sound blankets
- Coil coating - 6,048 hours salt spray effectiveness
- Freezestat, high and low pressure switch

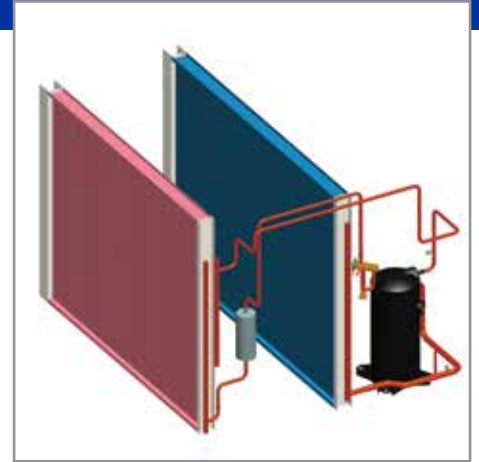

A wide range of benefits for a wide range of applications.

Applications that require 100% outside air place a strain on equipment because of the extended run times. In a typical hotel corridor installation, the units run 24 hours a day, 7 days a week. YORK units are robust and designed for extended use.

- Foam panel double wall construction
- R13 insulation value
- Renewable/organic insulation material
- Safe bottom lifting
- Pre-painted G90 galvanized steel
- Hinged and lockable doors

The center of it all.

The supply fan is the heart of the system. Long lasting features include:

- Direct drive plenum fan
- VFD Control (standard)
 - Duct pressure control
 - Building pressure control
- Slide-out servicing
- Phase loss protection
- Power exhaust (optional)
 - Building static pressure
 - Supply fan tracking

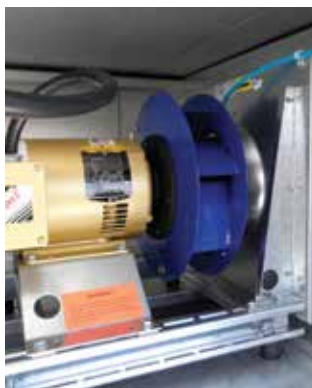

The best kind of energy is the kind you re-use.

The energy recovery module pre-conditions the fresh air by using energy from the exhaust air. The DOAS unit, with the energy recovery module, integrates this technology, allowing greater application flexibility.

- Integrated power, controls and mechanical
- ARI rated enthalpy wheel
- Superior sensible and latent performance
- Minimal cross contamination (less than 5%)
- Slide out servicing
- Optional low ambient control kit for temperatures below 10°F
- Electric preheat
- Standard filtration (MERV8)
- Standard barometric relief exhaust damper
- Can handle unbalanced air flows



Bring the fresh in.

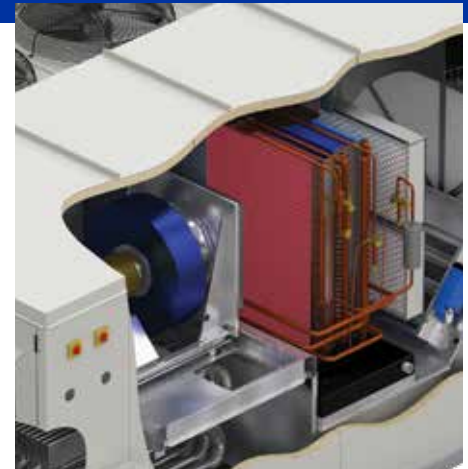

Easy-to-use, advanced controls.

Traditional control systems are pushed to their limits to accommodate 100% outside air applications. The DOAS unit features a control system specifically designed to meet these demanding requirements. It has the ideal blend of custom unit performance without overwhelming the user with unnecessary setpoints, menus and confusing complex sequences. When needed, the unit gives the right information at the right time.

- Standard unit mounted display
- Optional remote display(s)
- Native BACnet® & LON communication
- Test mode and start-up operation
- Controller level status lights
- Quick setpoint menus
- Permanent unit memory back-up
- Unit safeties
- Anti-cycle program

- Alarm & Recovery
 - High discharge air temperature
 - Low discharge air temperature
 - No airflow
 - Failed sensor(s)
 - Phase loss/brownout
 - Smoke
 - Mechanical heat
 - 5 alarms codes
 - 10 error codes
 - Mechanical cooling
 - 7 alarm codes
 - Intelligent system recovery

- Sequences of Operation
 - Neutral air control
 - Space temperature reset control
 - Tempered air control
 - Process control
 - Supply air constant volume
 - Supply air variable volume
 - Duct static & building static
 - Demand ventilation
 - Exhaust fan matching
 - Summer/winter fan speed
 - Space fan speed control
 - Manual & external control
 - Power exhaust control
 - Mixed air damper controls
 - Duct static & building static
 - Demand ventilation
 - Exhaust fan matching
 - Manual & external control
 - Energy recovery

Seamless BAS integration.

Modern buildings are relying more on building wide automation systems to maintain proper facility control. The native BACnet control system has been specifically designed to be integrated with building automation systems. LON protocols are also available. More importantly, the DOAS control system is intuitive and user friendly.



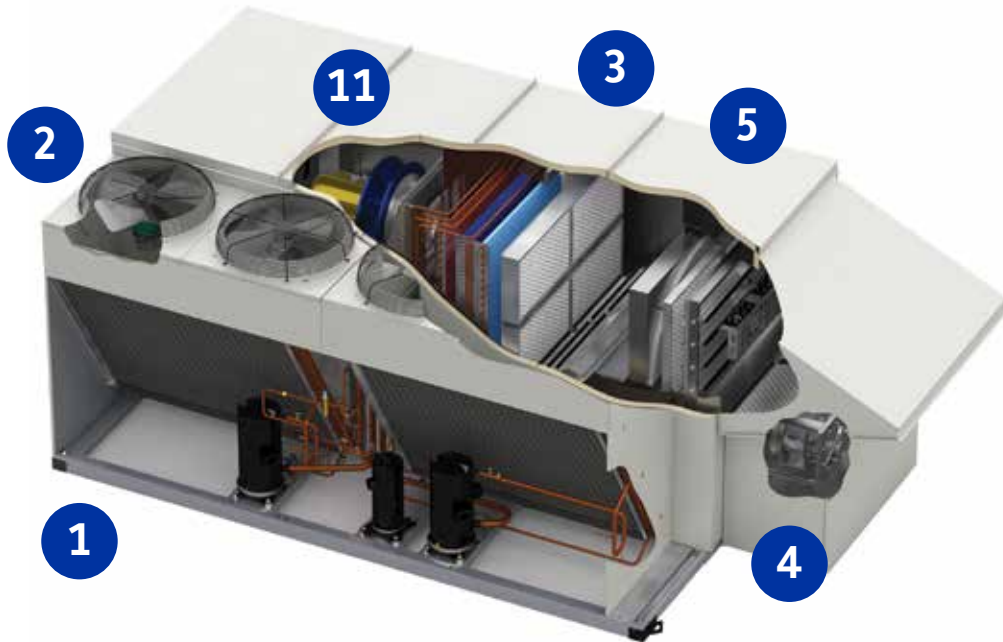

- 1. Energy efficient compressors
10-100% capacity modulation
- 2. ECM condenser fan motors
- 3. MERV 8 & 13 filters
- 4. ECM power exhaust
- 5. Outside air damper
Provides up to 100% outside air
- 6. Direct drive plenum fan
Variable frequency drive

- 7. Heat section
Gas or electric heat
Modulating or staged control
409 stainless steel heat exchanger
- 8. Fully interlaced DX coil
- 9. Independent modulating reheat circuit
- 10. Integral energy recovery wheel
- 11. Double wall foam panel construction
- 12. DDC unit controller

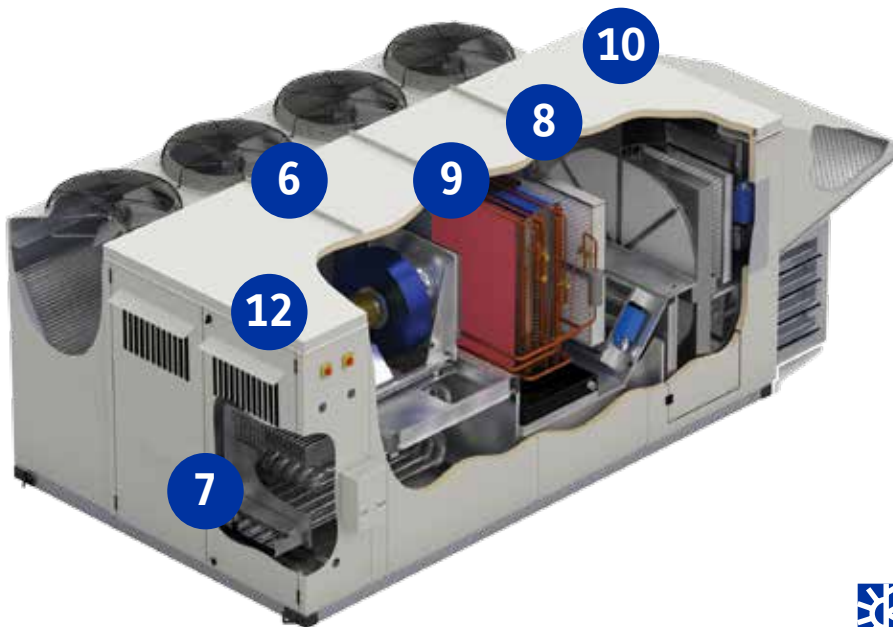

Bring the fresh in.

You can choose from a range of 100% outside air DOAS units to provide comfort for a wide variety of conditions. Select the right one for your specific application.

Model JDMA/JDHA		-060	-090	-120	-150	-180	-210	-240	-300	-360
Nominal Cooling Capacity Input	BTU	60,000	90,000	120,000	150,000	180,000	210,000	240,000	300,000	360,000
	Tons	5	7.5	10	12.5	15	17.5	20	25	30
Nominal Airflow	scfm (JDMA)	650-1500	975-1680	1300-3000	1625-3500	2000-4400	2275-5250	2600-5500	3400-7500	3900-9000
	scfm (JDHA)	750-1680	1290-2250	1500-3550	1875-3550	2250-5500	2625-5500	3000-5500	3750-8700	4500-9350
Gas Heat Size (see table below)	Standard Efficiency	H75-H300		H100-H400		H100-H500		H150-H700	H200-H800	
	High Efficiency	G150-G300		G150-G600		G150-G600			G225-G600	
Power	208/3, 230/3, 460/3, & 575/3 60Hz									

Size -060 also available in 230/1/60 power voltage.

Natural Gas or Propane Heating	Option Code	MBH	
		Input	Output
Standard Efficiency (80%)	H50	50	40
	H75	75	60
	H100	100	80
	H102	100	80
	H125	125	100
	H150	150	120
	H175	175	140
	H200	200	160
	H202	200	160
	H300	300	240
	H400	400	320
	H402	400	320
	H502	500	400
	H602	600	480
High Efficiency (90%)	G150	150	138
	G225	225	207
	G300	300	276
	G302	300	276
	G372	370	340
	G452	450	414
	G525	525	483
G602	600	552	



Printed on recycled paper.

BACnet® is a registered trademark of American Society of Heating, Refrigeration and Air-Conditioning Engineers (ASHRAE).

Johnson Controls and the Johnson Controls logo are registered trademarks in the United States of America and other countries. Other trademarks used herein may be trademarks or registered trademarks of other companies.

© 2015 Johnson Controls, Inc. P.O. Box 423, Milwaukee, WI 53201. All rights reserved worldwide. Printed in USA PUBL-7520 johnsoncontrols.com

