



Bravo-5

5 Amateur Band Vertical Dipole

20-17-15-12-10 meter bands

Latching Relays, 450W CW

www. n6bt .com

P.O. Box 1859 Paso Robles, CA 93447

e-mail to: tom@n6bt.com

Table of Contents

Overview and Product History
Basic Design Principles and Features
Assembly, Set-up, What If
Commonly Asked Questions, Tuning the Bravo 5
What to Expect in Terms of Performance
Performance Expectations and Plots
Short Explanation of Antenna Principles
How the Bravo Got Here
Drawings and Plots

OVERVIEW and PRODUCT HISTORY

Congratulations on your purchase of a next generation antenna by N6BT. In this case, it's a next generation vertical dipole, the Bravo-5.

The Bravo series has some important, fundamental improvements over older antennas. One is that it is designed to be the lowest cost to you, the customer. There are no "frills", such as powder coating (besides, its an insulator), no anodizing (its also an insulator) and no complex, mechanical joints, where something simpler will perform at least as well. Keeping it simple, the Bravo 5 uses easy-to-find compression clamps for section coupling, designed to be mostly field-repairable if need-be, basically "plug and play" and the highest efficiency possible. In simple economic terms, "The most bang for your buck!"

The Bravo series is another development by Tom Schiller, N6BT, who founded Force 12, Inc. back in 1992. He brought about a whole new



generation of antennas back then, including the first trap-less tri-band Yagi, multi-band Yagis of many variations without traps, new verticals and vertical dipoles. After producing about 24,000 antennas, he took a break and started a new venture in 2010 – n6bt.com – and the next generation of antennas was begun. After designing about 200 production antennas over the years, holding several radio patents, being an active DXer and contester with more than 20 world records individually and with Team Vertical, one would expect something new. Here it is.

Team Vertical began in 1997 and re-wrote the book on vertical antennas using creativity, empirical testing, plus building and using in competition more than 300 verticals. Much of the Team's history is contained in N6BT's latest book, Array of Light Third Edition 2010. One of the antennas that was developed with the Team and used to set many records on 40 and 20 meters was the called "Sigma" vertical dipole. It was given that name because it was the sum of what N6BT knew about verticals at that time. It was produced in many models from 80 meters up through 70cm. Another model was remote-switched for 5 bands, 20 through 10.

The 5-band vertical dipole was so good that it was even copied by at least one other company. Now after a break of a couple years to distill thoughts, the Bravo-5 is the next generation – a vertical dipole that is not only improved mechanically and visually, but also performance-wise.

The Bravo-5 is physically full size on 10 and loaded with high-Q coils for 12, 15, 17 and 20 meters. There are two segments on 20, providing full band coverage.

BASIC DESIGN PRINCIPLES and FEATURES

How to describe the Bravo series has been a bit of a challenge and the best description is that it is a vertical dipole with asymmetric feed and compressed length tubing radials. The last part first: vertical dipole.

A full size, straight vertical dipole is basically a half-wave dipole turned vertically and fed in the center, just like it would be as a horizontal dipole. In the horizontal configuration, it has a feed impedance of about 70 ohms, depending on its height above ground. In the vertical position, it has a feed impedance of around 90 ohms, giving a VSWR to 50 ohm coax of about 1.8:1. Nobody likes that very much, as the VSWR isn't that coveted 1:1, so we shorten the length to move the feed impedance down to around 50 ohms. This is done in collaboration with the vertical section and the radials. Since there is no end loading at the top (no cross bar at the top of the vertical portion), the Bravo vertical section is made longer than one that is top loaded.

The new Bravo vertical section is mechanically and visually superior. Rather than having the heavier vertical section to hold up the top cross bar, the Bravo vertical section is tapered, which gives a smaller visual footprint and also less wind load, while maintaining the performance characteristics of the top loaded vertical dipole. Making the vertical section on

the Bravo also moved the feed point to the bottom, not at the center of the previous design. This is much more user, visually and mechanically friendly.

The Bravo's two (2) tubing radials are shorter than full size. The appropriate length to have a 50 ohm feed impedance for the vertical dipole is made up in the vertical length selection. The tubing radials are loaded very slightly on 10 and 12 meters. This places the feed point not at the typical, physical center; therefore, it is asymmetric. The loading in the radials and the loading in the vertical section are not identical.

Putting the above together into the next generation, the Bravo-5 has these improvements over the previous designs:

a) mechanically

- __single vertical element without the top end loading bar, making this antenna easier to build and erect, with less wind loading and, therefore, stronger in bad weather, without the tendency to rotate in the wind (as often happens with the top end loading cross bar);

- __safety-tilt radials slope downward from the main hub. The slight slant catches one's eye, so it is easier to see and less likely to bump in to;

- __the tri-pod was always an option, but not any more – it comes with the antenna

- __box containing the loading coils has a weather-sealing gasket

- __box cover is easily removed for control cable connections, or to manually function the relays with a separate battery

- __stainless hardware is used where it should be used

b) electrically

- __feed point is at the bottom, right where you want it

- __the feed line can now be dropped straight down – no more sloping off at a 45° angle

- __all loading is right at the bottom, within easy reach

- __the Bravo-5 uses latching relays, so the power is only applied for a short pulse and not continuously to remain on a band

- __the relay box can be controlled right at the antenna using a separate battery

- __the relay box is diode-protected so the voltage cannot be applied in the wrong polarity

c) performance

- __efficiency is on the order of 92% on 20 meters, increasing rapidly on 17 and being about 98-99% on the higher bands

- __actually has slightly more gain than the older series with the top end loading bar.

d) cost – low cost and field repairable are major design goals

- __the "most bang for your buck"

- __use your own control cable – it connects to (2) European style barrier strips.

- __simple, easy to get compression clamps

- __no need for powder coated or anodized parts

- __keep it simple

SPECIFICATIONS:

Overall height will all vertical sections = ~9'

Overall radial length with all sections = ~5.5'

Weights: vertical sections = 1.5#, radials (2) = 2#, hub = 1.5#; tri-pod = 2.5# Total = 7.5#

VSWR on all bands is 1.3:1 or less at resonance

Power rating = 450w CW

Computed efficiency:

	Efficiency %	Total Loss in the Antenna
10 meters	99+%	-0.01dB
12 meters	99+%	-0.02
15 meters	98 %	-0.06
17 meters	96+%	-0.14
20 meters	92 %	-0.35dB

Please be aware that there are emission exposure limits set by the FCC. All ground-based antennas will emit more energy at "people" level than elevated ones. Since this antenna is probably going to be used at ground level and possibly close to people, be careful to keep the power level as low as practical.

Let's put it together.....

ASSEMBLY

1. TOOLS and PARTS REQUIRED

- A. Tools required:
 - 1) blade screwdriver for compression clamps
 - a) can also use nut drivers on the compression clamps
 - b) they will be the #6 (1/4" dark red) and #8 (3/16" orange)
 - 2) nut driver for #10 nuts (3/8" – blue handle)
- B. Other
 - 1) tape measure
__Note – for portable use, a tri-pod leg or the first long section on the radials (the .500" section) can be calibrated for the measurements you will need. The maximum is measurement anywhere is 33".
- C. Hardware
 - 1) The majority of the hardware is stainless steel, except possibly for some of the components in the compression clamps. They are available in all stainless steel for harsh environments.
- D. Coax feed line with a UHF PL-259 connector
 - 1) Coax should be 50-ohm, such as RG-8X, RG-58, RG-8
 - 2) To keep the product cost as low as possible, this antenna is shipped with an

integrated balun composed of ferrite beads inside the relay box.

SET-UP

2. ANTENNA AND TRI-POD

- ___ A. This antenna has been fully assembled and tested before shipping
 - 1) all the compression clamps are in place on the sections of tubing
 - 2) the tubing sections are telescoped inside each other
 - 3) the coils inside the coil box have been pre-set

- ___ B. Please follow the drawing that gives the tubing length settings
 - 1) Snug the compression clamps to secure the sections – just enough so the section(s) won't slide, or turn
 - 2) No need to "crunch" the clamps.
 - 3) Nut drivers are the best method for managing the compression clamps
 - 4) Using a spray lubricant, such as WD-40 or Tri-Flo will aid in keeping the sections easy to move. WD-40 will disappear over time and need to be replenished.

- ___ C. Your particular installation is most likely not like our test facilities, so the antenna might not be exactly on frequency.
 - 1) If necessary, please follow the frequency adjustment procedure later in this manual

- ___ D. Plug the legs into the tri-pod base. The legs simply slide in. If you like, tape can be used to secure them.

- ___ E. Slide the assembled antenna into the tri-pod. The compression clamp on the top of the tri-pod can be tightened as desired to keep the antenna from rotating in the wind.

- ___ F. The Bravo-5 should be guyed at the base of the vertical section when installed in windy locations. Use non-conductive line – not metal guy cable.

3. CHANGING BANDS

- ___ A. The relay box can be controlled from the control box via the control cable, or right at the relay box using a separate battery.
 - 1) The relays are latching, so the voltage is only for a pulse to either reset the relays, or set them again.
 - 2) The relay box is diode-protected so the voltage cannot be applied in the wrong polarity.

3) The relays pull in at about 8.5VDC. There are either one or two diodes that appear in the control circuit. This means there is a maximum voltage drop of about 1.5V. The minimum supply voltage at the relay box (not at the control box), will be a 10VDC. A brand new 9V battery might have enough voltage to cycle the relays right at the relay box.

___ B. The control cable requires 7 conductors and 12VDC at the control box for typical control cable lengths.

- 1) This cable can be small conductors, as the current requirement is quite small, plus only being a pulse. Using typical 8-conductor rotator cable is great and using a pair of the small 4-conductor telephone cables will work, too. When using 8-conductor cables, double up on the ground (-, negative) lead.
- 2) Connect your cable to the control box, following the wiring diagram.
- 3) Connect the cable to the antenna relay box, bringing it up through the hole and then to the barrier strip terminals.

___ C. The coil box cover can be left off if desired

- 1) there is a gasket for the coil box cover to assist in weather-sealing
- 2) there are (4) screws for the coil box cover for permanent installations
- 3) if you do not seal the cover, place the gasket and screws in a safe place you can find when you want them

___ D. To change bands using the control box

- 1) be sure it is connected properly to 12VDC (typically 13.8 if used to power the rig) supply
- 2) press the "RESET" push button. The left-hand light will light and the relays in the relay box will be reset to their unlatched state.
- 3) select the band of choice using the rotary switch
- 4) press the "SET" push button. The right-hand light will light and the appropriate relays in the relay box will be set

___ E. To change bands right at the relay box using a separate battery

- 1) the battery leads need to be touched to the proper barrier strip connections
- 2) to reset the relays, touch the battery negative lead to the ground terminal and touch the positive lead from the battery to "20L" on the terminal strip.
- 3) to select the band of choice, touch the battery negative lead to the ground terminal and touch the positive lead from the battery to the terminal corresponding to the band of choice.

___ F. Note – if the antenna is knocked over, or falls down, the relays might unlatch. In this case, simply reset the relay box and set your band again.

4. WHAT IF

___ A. What if the VSWR is way high, like 3:1 when I hook it up?

1) Most likely this is a coax feed line problem. Check for continuity through the coax connectors and be sure the shield and center conductor are not shorted somewhere.

— B. What if when I use a meter to check tuning, I can't get it to work right?

1) Meters, like the popular MFJ, can have a couple conditions where they are not useful.

2) Meters send out their own, very low power signal and read the "return." If there happens to be additional RF nearby, such as from AM broadcast, the meter might be completely ineffective, as it will also receive the Rf from the broadcast station. This is because the meters normally have a wide-open front end and receive everything.

3) On the MFJ dual meter device, people will sometimes use the righthand meter that is calibrated in ohms to tune an antenna. They will move the tuning knob until the meter reads 50 and then read the frequency, plus reading the VSWR on the lefthand meter. The lefthand meter will more often than not, read a high VSWR. This is an incorrect procedure.

a) Use the lefthand meter only to tune an antenna. Tune the knob carefully and slowly, looking for the dip in the lefthand meter. Set the tuning for the lowest point in the meter's reading and you will have both the frequency of the antenna and its associated VSWR at that frequency.

5. COMMONLY ASKED QUESTIONS

— A. Do I need to change the antenna to go on another band?

To listen on another band, you can use the antenna on whatever band it is tuned for. It will not be as effective (i.e. sensitive) as when it is properly tuned.

— B. Can I use a tuner with the antenna?

It should not be necessary, unless you want to operate outside an amateur band. In this case, it would be wise to use reduced power.

Using a tuner on either receive and transmit will not be as efficient as when the antenna is properly tuned.

— C. Do I need radials with the Bravo-5?

No – although the Bravo-5 might resemble a general design of a $\frac{1}{4}$ wavelength vertical with 2 radials, it is actually an asymmetrically fed, loaded radial vertical dipole. It is "self-contained" and does not need any additional radials.

— D. Can I add radials under the Bravo-5 to improve the ground conductivity?

Absolutely!

The efficiency of the antenna is always a constant, regardless of the ground or surrounding area / terrain. The ground does have a significant contribution to the efficiency of the antenna system, which is not only the antenna, but also the ground and surroundings. Objects like nearby metal buildings usually are detrimental, as they can block signals, both coming and going.

The conductivity of the ground is a major contributor to the system efficiency. If the ground is extremely poor, such as granite, the vertically-polarized energy of the antenna is negatively enhanced. If, on the other hand, the ground is rich dirt, it is much better. The ultimate for a vertical is salt water, which both creates essentially a loss-less near-field for the energy, but also an unobstructed plane going out for some distance.

The result of poor vs. great ground is the low angle energy. As the ground is improved, the low angle energy is increased. Salt water, for example, can support energy down to perhaps 1 degree.

If you are not enjoying the beach and have the Bravo-5 in close proximity to salt water, you can take random lengths of wire and run them away from the base of the antenna. The lengths are not critical. In general, the more wire, the better, as compared to a few long runs. Do not connect them to the antenna!

Regarding verticals and salt water – my book, *Array of Light* has a lot of coverage on this subject. Briefly, the antenna needs to be quite close to the water. Team Vertical installs our competition antennas within $\frac{1}{4}$ wavelength to in the water (above, of course) whenever possible. A distance of $\frac{3}{4}$ wavelength from the salt-water boundary is about the limit. For reference, a distance of $\frac{3}{4}$ wavelength on 20 is about 52'. A $\frac{1}{4}$ wavelength would be about 17'. Remember to take into account surf, general wave action and tides. To calculate a half wavelength on any frequency for this purpose, divide 492 by the frequency in MHz – right, 492, not 468. The latter number is for a wire antenna and takes into account the probable velocity factor of the wire. We are dealing in air.

How much improvement might you get from adding wire? In carefully run tests, we have measured 2-3dB improvement when the antenna is over good ground. If it is over incredibly poor ground, it was more like 8-10dB, which seems impossible, but it was due to the low angle energy being “recovered” by the improved ground conductivity.

6. TUNING THE BRAVO-5

- _____ A. If the Bravo-5 is not on frequency, meaning that it does not cover the selected band with a reasonable VSWR (i.e. best VSWR is way low below a band) is this section.
- _____ B. The Bravo-5 comes already tested and tuned. It is certainly possible that the antenna will tune up differently in all the combinations of locations, such as height above ground and the characteristics of the ground.
- _____ C. Please remember that an antenna does not need to be 1:1 VSWR point to work properly. (N6BT's great book on antennas, *Array of Light*, Third Edition, cover this is

detail.)

1. A VSWR below 2:1 should be fine for most equipment and is not indicate the antenna is operating poorly. All it means is that the feed point is not matched to 50 ohms. A 2:1 VSWR will mean it is either 2 times or $\frac{1}{2}$ of 50 ohms and in this case, it will be the latter, $\frac{1}{2}$ of 50 ohms, or about 25 ohms. This is often a result when the antenna is being used at higher heights above ground.
2. The installed hairpin matching coil (soldered onto the PCB) can be adjusted by expanding the turns on the coil. Expand the turns slightly and note if the VSWR improves. If does, then continue to expand the turns.
3. If expanding the turns on the hairpin matching coil results in a higher VSWR, please e-mail tom @ n6bt.com

_____ D. If one or more of the bands are significantly off frequency (i.e. the lowest VSWR is obviously way out of the band and the VSWR is higher than 1.5:1) the coils for the bands need to be adjusted. Please do it carefully.

1. the coils are in sequence and add together. This means that 15 meters uses the 12 meter coil and the 15 meter coil. 17 meters uses the 12, 15 and 17 meter coils.
2. since the coils are additive, they must be adjusted in sequence

_____ E. To begin, reset the relays – this will place the antenna in 20 LOW

1. next - set the relay box to 10 meters
 - a) there are no coils in the circuit when on 10 meters
 - b) this is the "native mode" of the antenna, which means it is the antenna as it is physically built, along with the stray inductance in the relay box
2. the point of lowest VSWR is set at the factory to about 28.300 MHz and should be minimal, if at all – the antenna is extremely broadbanded on 10 meters and can cover down to almost 27 MHz and up to almost 30 MHz
 - a) to change this frequency requires changing the length of the radials, the vertical section, or possibly both
 - b) change the length of the radials first
 - 1) lengthening the radials will lower the frequency and there is not much adjustment available
 - 2) shortening the radials will raise the frequency
 - 3) the same holds for the vertical sections and adjusting the vertical sections will make a more rapid change than changing the radial lengths

_____ F. To set the remaining bands – again, it is not necessary to be "exactly perfect" on the frequency settings. The antenna is broadbanded and the VSWR should be about 1.5:1 or less across the bands, except for 20 meters

1. set the relay box to 12 meters
 - a) adjust both 12 meter coils for about 24.925 MHz
2. set the relay box to 15 meters

- a) adjust both 15 meter coils for about 21.225 MHz
- b) do not go back and adjust the 12 meter coils
3. set the relay box to 17 meters
 - a) adjust both 17 meter coils for about 18.125 MHz
 - b) do not go back and adjust the 12 or 15 meter coils
4. set the relay box to 20 LOW (this is the same as hitting "RESET")
 - a) the 20 meter band is covered in 2 segments and this will set the lower frequency
 - b) adjust both 20 meter coils for about 14.150 MHz
 - c) do not go back and adjust any other coils
5. set the relay box for 20 HI and check the frequency. It should have moved up to cover the phone portion of the band.

WHAT TO EXPECT IN TERMS OF PERFORMANCE

Vertical antennas installed not far above ground will have a single energy lobe coming off at about 20 degrees. If the vertical antenna is installed over salt water, or very close to it, this energy lobe will be lowered considerably, with energy now down to about 1 degree, which is as good as it gets. Horizontal antennas, even stacked Yagis, cannot compete with verticals and vertical arrays over salt water. This vertical antenna has a small footprint and will perform quite well when properly installed. It is the product from almost 20 years of using vertical antennas in world-wide competition by Team Vertical. As mentioned earlier, the Team has set more than 20 world records and re-wrote the book on verticals. Much information on verticals that you won't find any other place is contained in N6BT's book, Array of Light, Third Edition.

The ground under the vertical can be improved, especially when it is installed over sand or rock (granite is quite poor). Laying wire down underneath the antenna in length as long as practical and as many wires as practical, will improve the ground conductivity in what is called the "near field." This is the area closest to the vertical and is where the most loss in the ground will occur. Improving the ground will reduce these ground losses, with improved system performance and even a lowering of the lobe. "System performance" includes the antenna and the ground. The efficiency of the antenna itself will be constant, so improving the ground conductivity pertains to the ground portion of the system.

Q: How is a vertical compared to a horizontal antenna, such as a full size dipole (e.g. not a Windom, which is more of a top loaded wire vertical)?

Vertical antennas over ground will do a good job, especially considering their small footprint. A good, full size dipole at a reasonable height and in the clear will often be more effective than a vertical. The dipole will favor the stations off to the sides, because the dipole is directional. A horizontal dipole will have nulls off the ends and the depth of the nulls depends mostly on the height above ground and also surrounding objects. A vertical is omni-directional, meaning

it emits and receives energy equally in all directions.

SHORT EXPLANATION OF ANTENNA PRINCIPLES

Verticals over ground will lose some energy into the ground, which is why the ground should be as good as possible; good = electrically good and a metal roof is quite nice for this purpose. Salt water is incredible. In a different manner, the horizontal antenna will gain energy from ground effects, called "ground reflection gain." In practical terms, a horizontal dipole will achieve about 2dB gain compared to the isotropic source (properly stated 2dBi) due to the pattern being made into a figure 8 when the dipole is above ground. The side energy of the dipole, however, is reduced in order to achieve this 2dBi improvement.

If we begin with what is called the "isotropic radiator" (strictly theoretical), it is a sphere, with a single point source of energy located exactly at the center. It is emitting energy equally in all directions until it runs out – which is the skin of the balloon. It is also located out in "free space" and looks like this photo:



The horizontal antenna is, of course, not located in free space, but over ground. This causes the energy in the balloon to be redistributed like the next photo. As you can see, the balloon has been reformed, with more of it in 2 directions, which are broadside to the dipole. There is less energy where Tom's fingers are squeezing the balloon, which is in the direction of the ends of the dipole. By the ground effect of redistributing the energy, the dipole has 2dB gain over the isotropic source. This is known as 2dBi – 2dB compared to the isotropic source.



The horizontal will also benefit from ground reflection gain on the order of 5dB. This is the effect of reflected energy combining way out, in the "far field." If the vertical were perfect, in terms of not losing any energy to the ground, but still being over ground, the vertical will be about 7dB behind the dipole (2dB + 5dB). The take-off angle of the antennas comes into play here and although a single vertical will typically be less than a good horizontal antenna, adding a second element to the vertical will improve its performance by about 4dB and make it a directive array, as well.

ANTENNA PLOTS

There are several pages of computer antenna models in this manual. Each page contains much information concerning the probable performance of the Bravo-5K vertical.

If you are interested in adding a second element for an array, or making a larger array, please

send off an e-mail. We will be glad to assist you.

We can also provide information for you on your DXpeditions.

Thank you for selecting our product and let us know how it performs for you!

-----NOTICE-----

BE SURE THIS ANTENNA DOES NOT COME NEAR TO, OR IN CONTACT WITH POWER LINES, AS YOU CAN BE SERIOUSLY INJURED OR KILLED.

BE AWARE OF OTHER DANGERS AND ALWAYS CHECK THE AREA MORE THAN ONCE BEFORE ERECTING ANY ANTENNA.

Supplier: www.n6bt.com Warranty and Limitation of Liability

The supplier warrants its products for a period of one year from date of purchase. This warranty covers defects in manufacturing and workmanship. The supplier has the discretion of honoring the warranty if the product appears to have been abused, used in a manner that exceeds the specifications of the unit, or a use for which the product was not designed. This warranty does not cover transportation, installation, punitive, or other costs that may be incurred from warranty repair, or installation. The supplier must be notified and warranty repair authorized (only by the supplier who will issue a return material authorization, an RMA) before the supplier will accept any product returns. Please advise the date of purchase, model number, serial number if there is one and a brief description of the problem. There is a 30% restocking fee on products returned unused with an RMA issued by the supplier, at its sole discretion.

The customer, installer and user of these products individually and collectively acknowledge that these products can cause injury or death and individually and collectively accept full responsibility and liability for any and all personal and property damage (direct, indirect and punitive) caused during installation and/or use of these products and hold the supplier harmless for such damage.
(warranty notice date 4/1/2010)



The Bravo Series

How it got here.
(page 1 of 2)

What makes the Bravo the "Next Generation"?

One item is low cost -- it is easy to add cost into a product and very difficult to keep it low while maintaining performance. For example -> no expensive powder coating, which is an insulator and impossible to repair in the field.

Another is the basic design -- it is a new one, developed from more experience with Team Vertical over the past 2 years (2008-2009). It might be mistaken for what looks like a ground plane type vertical. A ground plane, of course, is a 1/4 wavelength vertical radiator fed against a pair of 1/4 wavelength radials. A quick look at the Bravo will show this is not the case. A ground plane vertical also has a feed impedance in the low 30-ohm range and the Bravo design is much higher, in the 50-65 ohm range for the full size Bravo's.

The vertical portion on the Bravo is fed at the bottom and the "radials" are fed at their common junction. If this were a typical, full size 1/4 wavelength vertical, the unmatched (native) feed impedance would give a VSWR of about 1.6:1. A full size Bravo, on the other hand has a native impedance over 50 ohms. It also has a vertical portion longer than a 1/4 wavelength and has a pair of "radials" that are much shorter than 1/4 wavelength. They are loaded at their center, with the result that the Bravo requires much less installation space. I put the word, "radials" in quotes, as they are not the best words to describe them, but they are the most convenient. They are not, however, a conventional type, as they are loaded, sloped and made of tubing. Maybe we should invent a new word for them in the Bravo design.

Let's take a couple steps back --

The previous generation before the Bravo was the "I" style and it was developed to be mechanically simpler to build than the "ZR" series vertical dipole. The original ZR specification was to have a high efficiency vertical without radials. It was composed of a vertical section and loaded at both ends using tubing in the shape of a square - an open-ended loop. It was built in single band designs and also a 20-15-10 meter model. They looked like this:



A single band ZR for 20 meters that is 6' tall. The feed is less than 50 ohms and is matched with a simple hairpin.



A original 20-15-10 mtr ZR at is 6' tall. This is 1500 watts mobile in the CQP sitting in Butte County.



A set of (4) 40 mtr ZR's are assembled and ready to be set up in Jamaica for Team Vertical who set a multi-op CQWW CW World Record.

The ZR's were built for amateur and commercial, with long term commercial testing documenting their high efficiency. Unfortunately, they were very difficult to manufacture, so over the years, more design work and experimentation led to the testing by Team Vertical of a new that we later called the "Sigma" series. It also was a center-fed vertical dipole, but the upper and lower loading square tubing loops were replaced by single horizontal bars, later dubbed, "T-bars." The full size models were set for 50 ohms and the shortened, loaded ones were matched with a simple hairpin. The photo at the right is the first set used, once again, in Jamaica and another record was set. The Sigma series was also built for amateur, commercial, plu smilitary applications. Frequencies covered from HF through UHF. Survival ratings were to 200mph and power ratings were to 10KW CCS.



The large size of the Sigma for 80/75 meters is what began the development of the asymmetric feed. This was about 36' tall, plus the base, making the center feed and loading point a long way up in the air. The feed point was moved downward, making it within reach on a tall ladder, but it created a small current imbalance of about 5% for the balun/RF choke to handle; it was a fair trade.

.....continued to page 2



The Bravo Series

How it got here.
(page 2 of 2)

The next couple of years (2008-2009) were used to further experiment with ways to improve the Sigma series. Several antennas were built and tested, particularly with Team Vertical again and all their expertise. These efforts were focused on improving it mechanically (mainly getting rid of the center feed), electrically and also achieving a visually smaller footprint, particularly for neighbors. Along with these criteria, the new design had to retain at least the same efficiency and overall performance. Enter the Bravo Series.

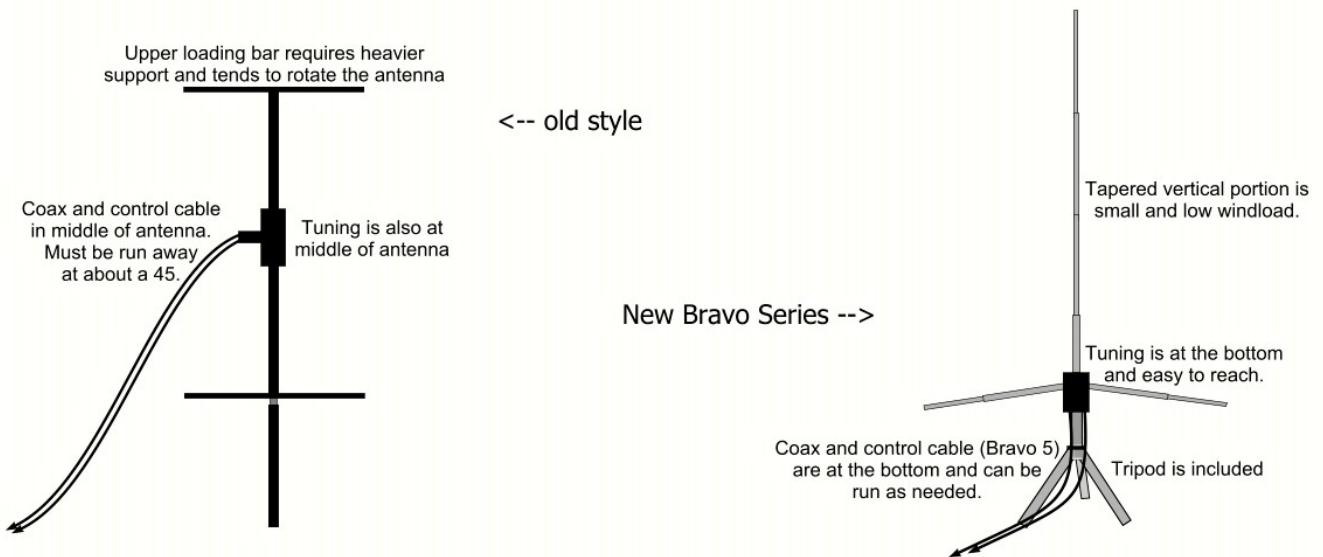

How long does it take to develop a new product? The visual below is a consolidated time line and through all these years, Team Vertical built and tested in competition more than 300 verticals and set more than 20 World Records. Many thousands of verticals were manufactured for the amateur and commercial marketplaces. Over the 16 years of founding and running Force 12, Inc., we built more than 24,000 antennas and developed many innovations and patented features. The new operations of founder N6BT will continue following the original goals of providing excellent products with accurate, true specifications. Enjoy the Bravo antennas !!



First 20-15-10 ZR-3 Vertical Dipole



Single Band 20 meter ZR



Reduced cost ZR-3 20-15-10



First 40 mtr ZR's Team vertical in 6Y M/M

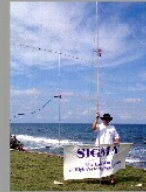

First "Sigma" design: 2-ele 40 mtr in 6Y



First 5-band "Sigma-5"



New Bravo Series

....starting about 1994.....~2000.....2001-2.....2010...

Statement during a software development meeting at IBM in the late '60's, "It is not possible to schedule invention."

n6bt-bravo-I-to-bravo-time-line-p2-rev1.0 Copyright, T.H. Schiller, N6BT 2010 No duplication of design or paperwork is authorized without written statement by T.H. Schiller, N6BT



Bravo 5

5-band vertical dipole, relay switched
 Covers the amateur 20-17-15-12-10 meter bands

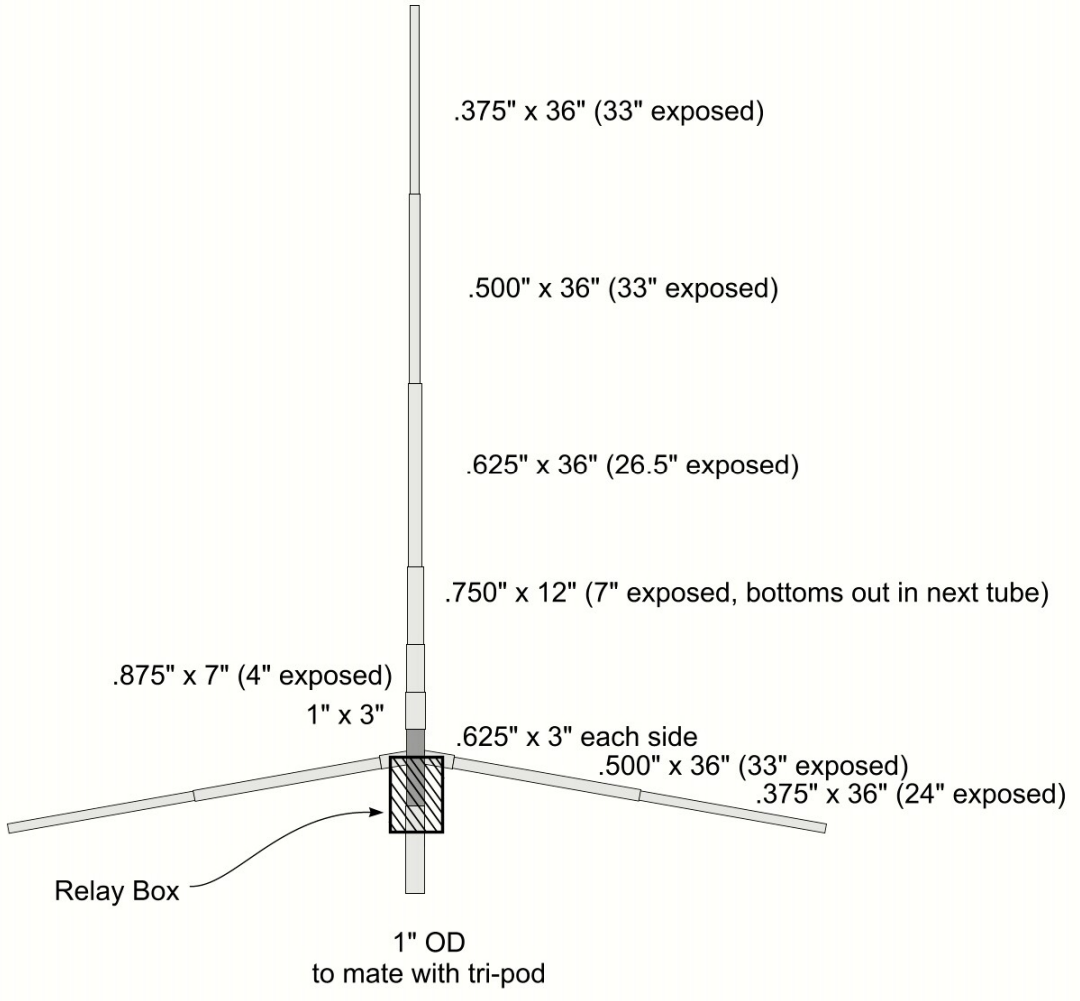

n6bt-bravo-5-d1-rev1.1
 Copyright, T.H. Schiller, N6BT 2010
 No duplication of design or paperwork is authorized
 without written statement by T.H. Schiller, N6BT



Bravo 5

5-band vertical dipole, relay switched
Covers the amateur 20-17-15-12-10 meter bands

Hub & Relay Box Detail

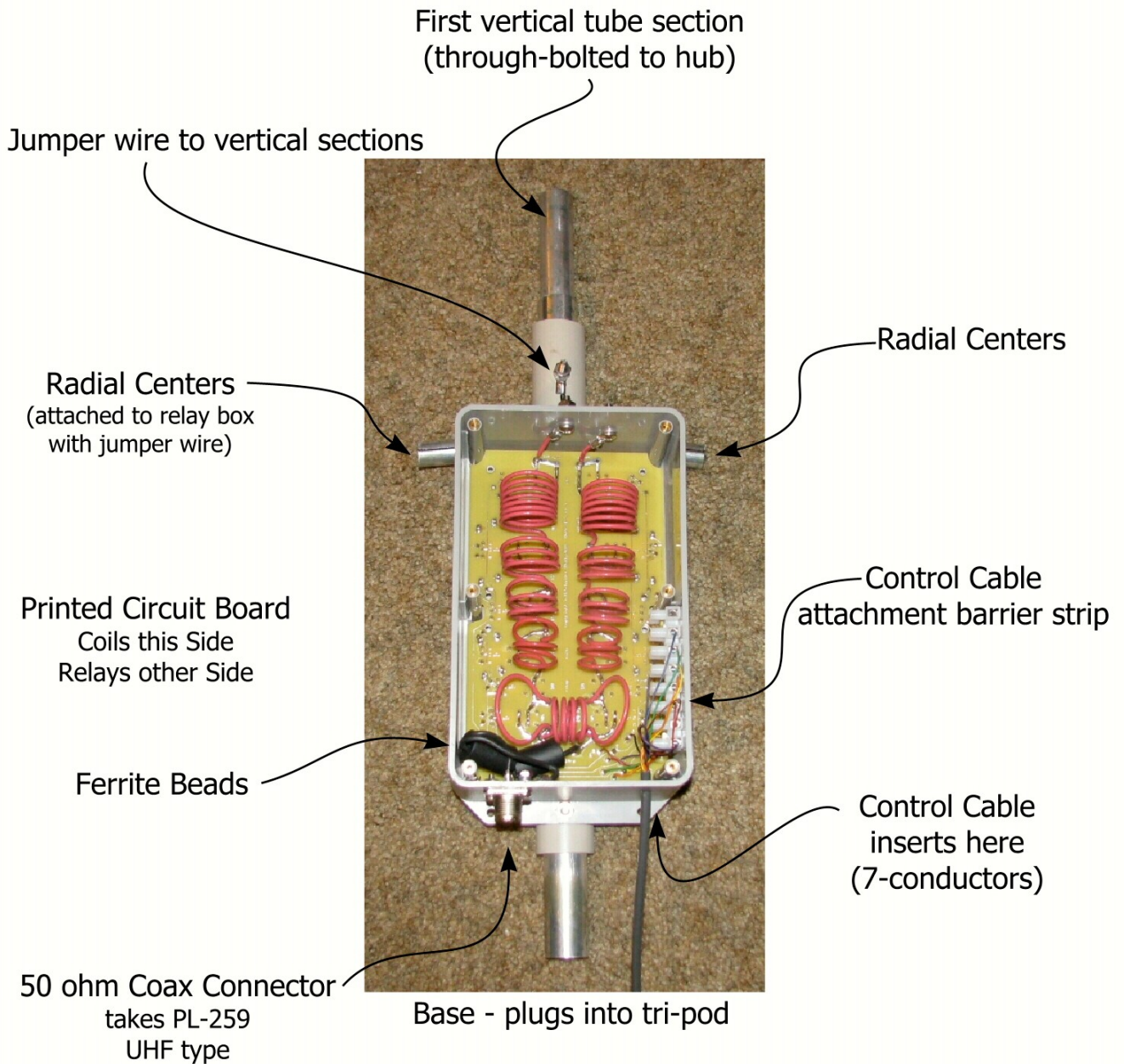

n6bt-bravo-5-d2-rev1.1
Copyright, T.H. Schiller, N6BT 2010
No duplication of design or paperwork is authorized
without written statement by T.H. Schiller, N6BT



Bravo 5

5-band vertical dipole, relay switched
Covers the amateur 20-17-15-12-10 meter bands

Relay Box Detail

Coils On

left side are for the radials ----- right side are vertical coils



tubing radial

tubing radial

20 meter coils

17 meter coils

15 meter coils

12 meter coils

20 meter
hi/low segment coils

Control Cable
connections

unused

10

12

15

17

20 Hi

20 Low

Ground (-)

50 ohm Coax Connector
takes PL-259
UHF type

Control Cable
inserts here
(7-conductors)

Common Hairpin
matching coil
for all bands

n6bt-bravo-5-d3-rev1.0
Copyright, T.H. Schiller, N6BT 2010
No duplication of design or paperwork is authorized
without written statement by T.H. Schiller, N6BT



Bravo 5

5-band vertical dipole, relay switched
 Covers the amateur 20-17-15-12-10 meter bands

Relay Box Adjustments

Coils On

left side are for the radials ----- right side are vertical coils

tubing radial
 20 meter coils
 17 meter coils
 15 meter coils
 12 meter coils
 20 meter
 hi/low segment coils
 ---note---
 not adjustable

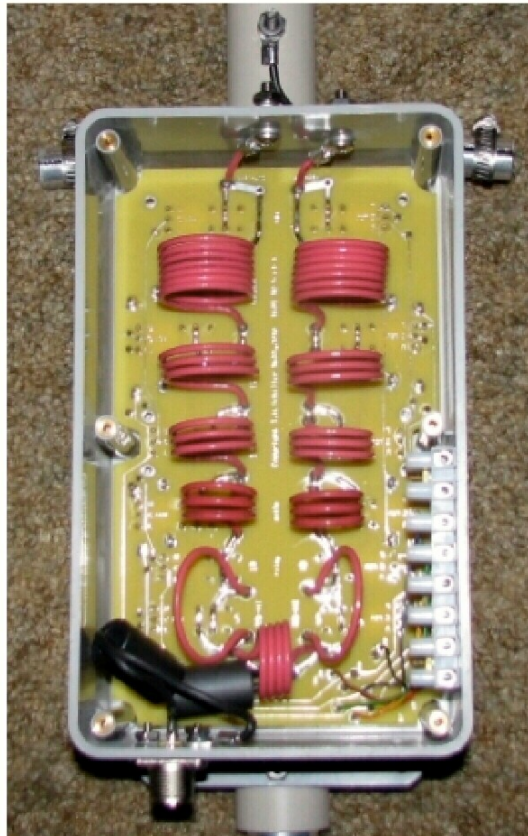

tubing radial
 Control Cable
 connections
 unused
 10
 12
 15
 17
 20 Hi
 20 Low
 Ground (-)

Procedure for coil adjustment

1. coils are in sequence and add to each other (i.e. 17 = 12+15+17)
2. make adjustment to highest band first, then on down through 20 meters
3. try to make adjustments equally on coil pairs (radial/vertical for each band)

If matching hairpin coil needs adjustment:

- a) coil comes compressed, which should work for a majority of locations
- b) if minimum VSWR is not less than 1.5:1, you can make an adjustment
- c) expand coil and if the VSWR improves, expand little more
- d) if expanding hairpin results in higher vswr, please e-mail tom@n6bt.com

n6bt-bravo-5-d4-rev1.0
 Copyright, T.H. Schiller, N6BT 2010
 No duplication of design or paperwork is authorized
 without written statement by T.H. Schiller, N6BT



Bravo 5

5-band vertical dipole, relay switched
Covers the amateur 20-17-15-12-10 meter bands

Control Box

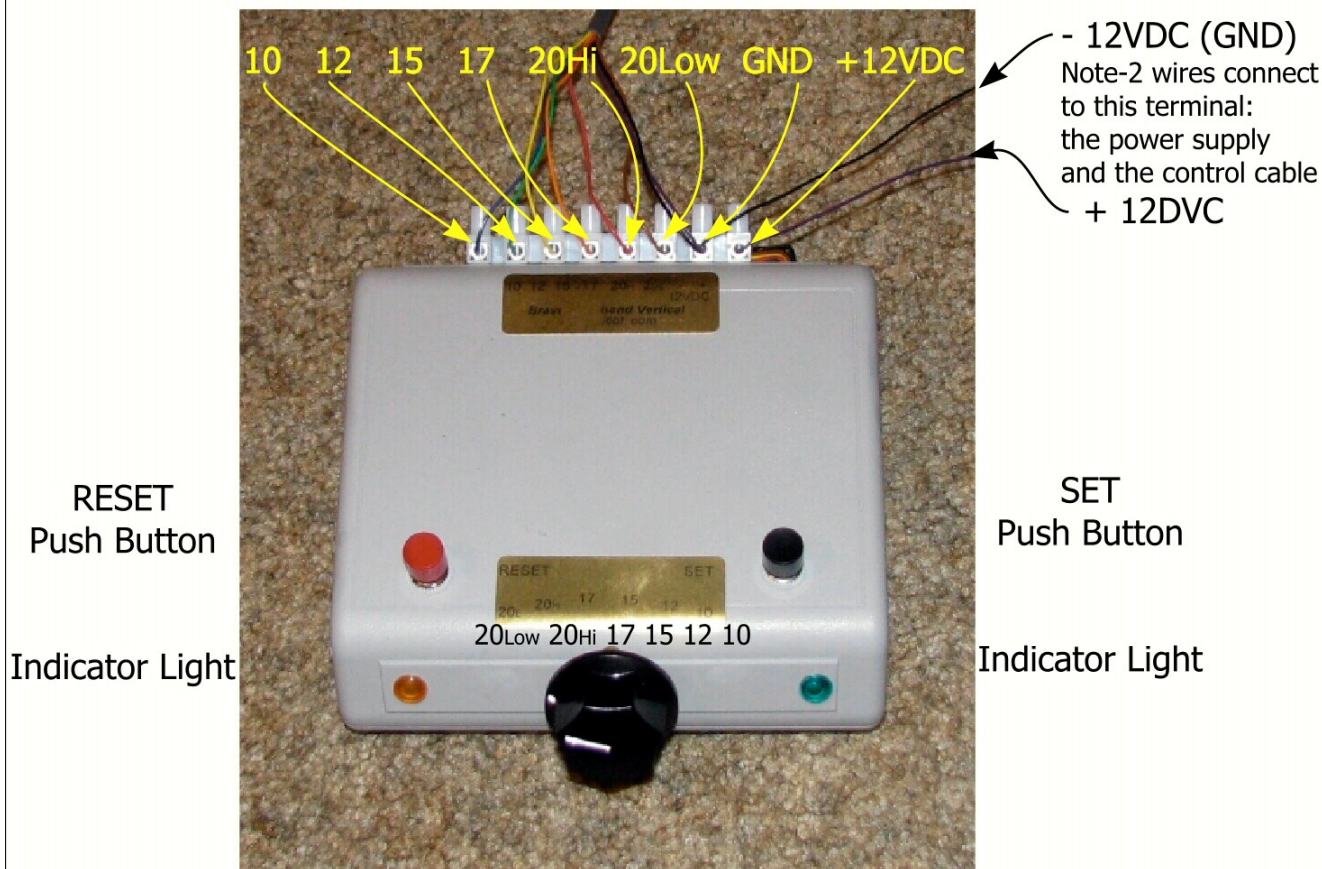

- 12VDC (GND)
Note-2 wires connect to this terminal:
the power supply and the control cable
+ 12VDC

RESET
Push Button

SET
Push Button

Indicator Light

Indicator Light

To change bands

1. be sure the power supply is attached and ON (12VDC to the + & GND terminals) and that the control cable is properly attached at the relay box at the antenna
2. press the RESET push button - the RESET indicator light will light - let off of the button (this also sets the antenna to 20 LOW)
3. Note - if the rotary switch is set to 20Low when the RESET button is pressed, the "SET" light will also light up, as resetting the relay box sets the antenna on 20Low
4. select the desired band on the rotary switch
5. press the SET push button - the indicator will light - let off of the button
6. the relays are now latched and will stay set until changed again
7. if the antenna is dropped, or falls, the relays might become unlatched - in this case, simply reset and set them again
8. the relays can be set at the relay box using a separate battery and touching the appropriate terminals: (-) and the band desired

n6bt-bravo-5-d5-rev1.1
Copyright, T.H. Schiller, N6BT 2010
No duplication of design or paperwork is authorized
without written statement by T.H. Schiller, N6BT



Bravo 5

5-band vertical dipole, relay switched
Covers the amateur 20-17-15-12-10 meter bands

Tri-Pod

with base tube for antenna and 3 slide-in legs

Base Tube - antenna slides in here



tri-pod leg slides in here

tri-pod leg slides in here

tri-pod leg slides in here

Usually, the weight of the antenna is sufficient to keep the legs in place. They can be taped. In windy conditions, the antenna can be guyed with non-conductive line just above the relay box; or, a weight can be tied to the welded plate on the tri-pod.

n6bt-bravo-5-d6-rev1.0
Copyright, T.H. Schiller, N6BT 2010
No duplication of design or paperwork is authorized
without written statement by T.H. Schiller, N6BT

Bravo Series Compression Clamp Information



Tubing ends have either (2) or (4) slots.

The photo shows tubing with (2) slots. On this type of tubing end, position the clamp body on the portion of tubing without a slot.

On tubing with (4) slots), the clamp position isn't as important; however, try to still place the clamp body *not* on a slot.



Bravo 5

5-band vertical dipole, relay switched
Covers the amateur 20-17-15-12-10 meter bands

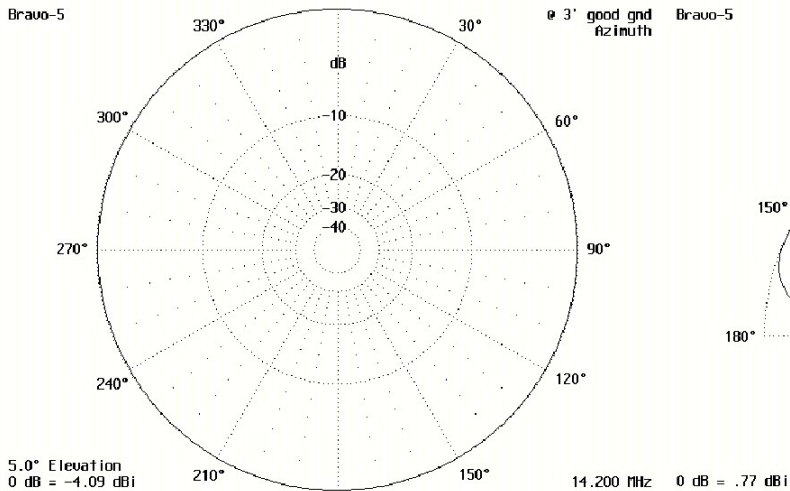

Typical omni-directional pattern looking down on the vertical

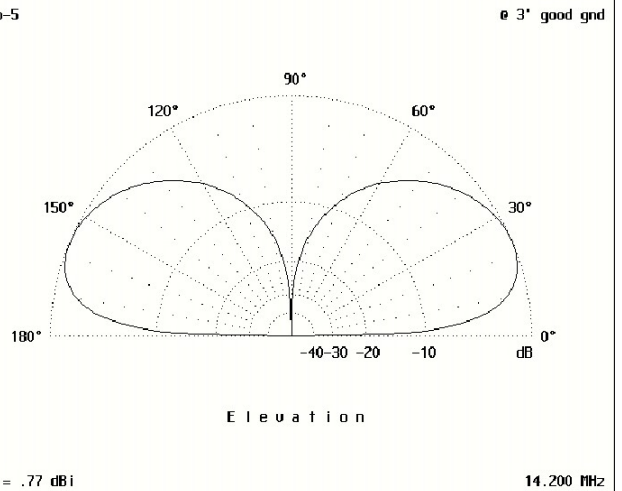

Elevation pattern for 20 meters, over ground, looking from the side.

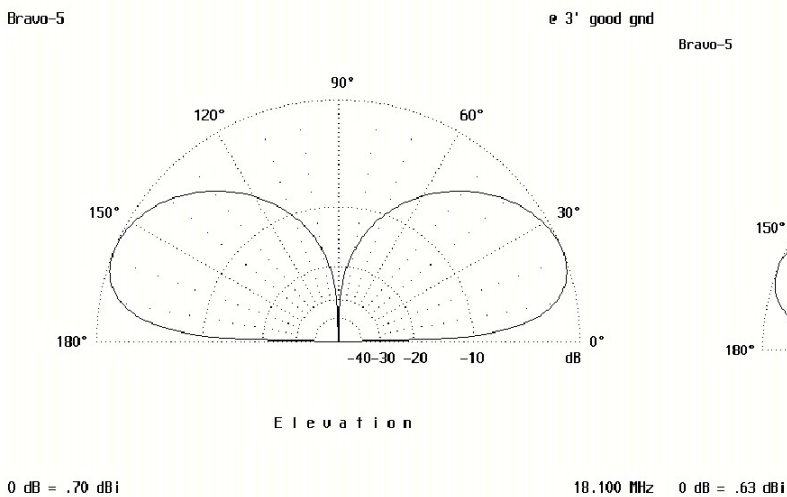

Elevation pattern for 17 meters, over ground, looking from the side.

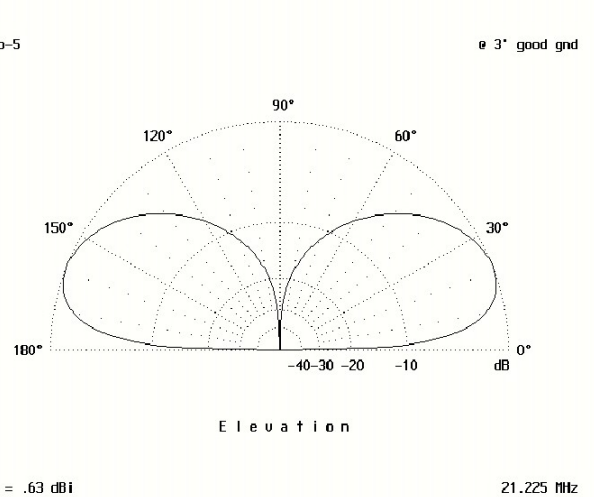

Elevation pattern for 15 meters, over ground, looking from the side.

n6bt-bravo-5-d7-rev1.0
Copyright, T.H. Schiller, N6BT 2010
No duplication of design or paperwork is authorized without written statement by T.H. Schiller, N6BT



Bravo 5

5-band vertical dipole, relay switched
Covers the amateur 20-17-15-12-10 meter bands

Bravo-5

@ 3' good gnd Bravo-5

@ 3' good gnd

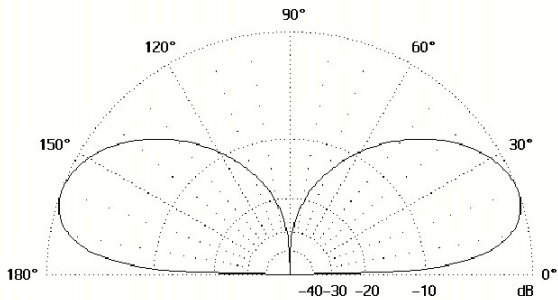

Elevation

0 dB = .58 dBi

24.925 MHz 0 dB = .61 dBi

28.200 MHz

Elevation pattern for 12 meters, over ground, looking from the side.

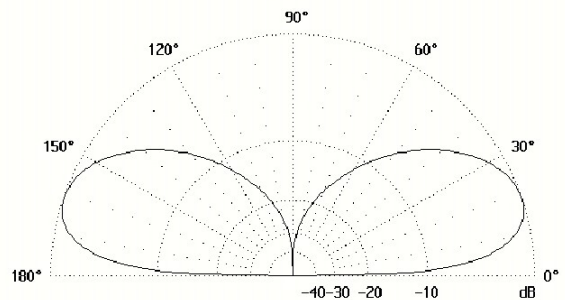

Elevation

Elevation pattern for 10 meters, over ground, looking from the side.

**A great way to get almost 4dB of gain on 20 meters:
space a pair of Bravo-5's at 35' and feed them in phase.**

BRAV05x2
BRAV05

@ 3' good gnd

BRAV05x2
BRAV05

@ 3' good gnd
azimuth

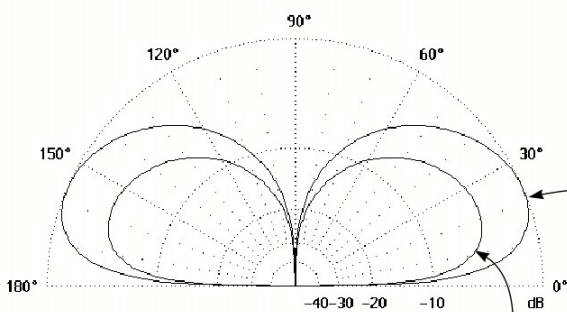

Elevation

0 dB = 4.57 dBi

14.200 MHz

5.0° Elevation
0 dB = -.29 dBi

14.200 MHz

Single Bravo-5

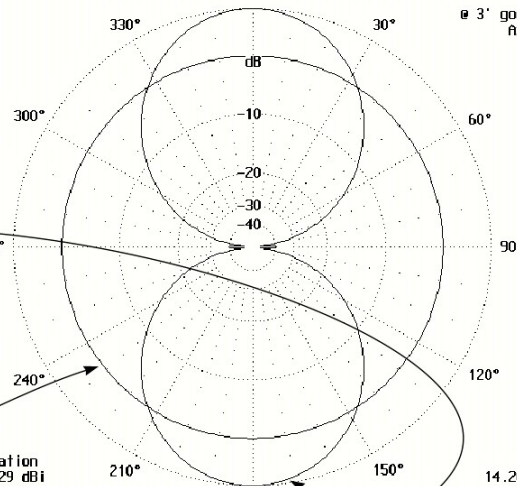

2 element Bravo-5

The 2 element has a 1/2 power beamwidth (-3dB from peak) of about 60 degrees.

This means the array needs to be aimed where you want it to go!

Note that it has gain in 2 (opposite) directions.

n6bt-bravo-5-d8-rev1.0
Copyright, T.H. Schiller, N6BT 2010
No duplication of design or paperwork is authorized
without written statement by T.H. Schiller, N6BT



Bravo 5

5-band vertical dipole, relay switched
Covers the amateur 20-17-15-12-10 meter bands

Comparison of Bravo-5 on 20 meters to popular, portable short dipole at its provided mast height of 8'

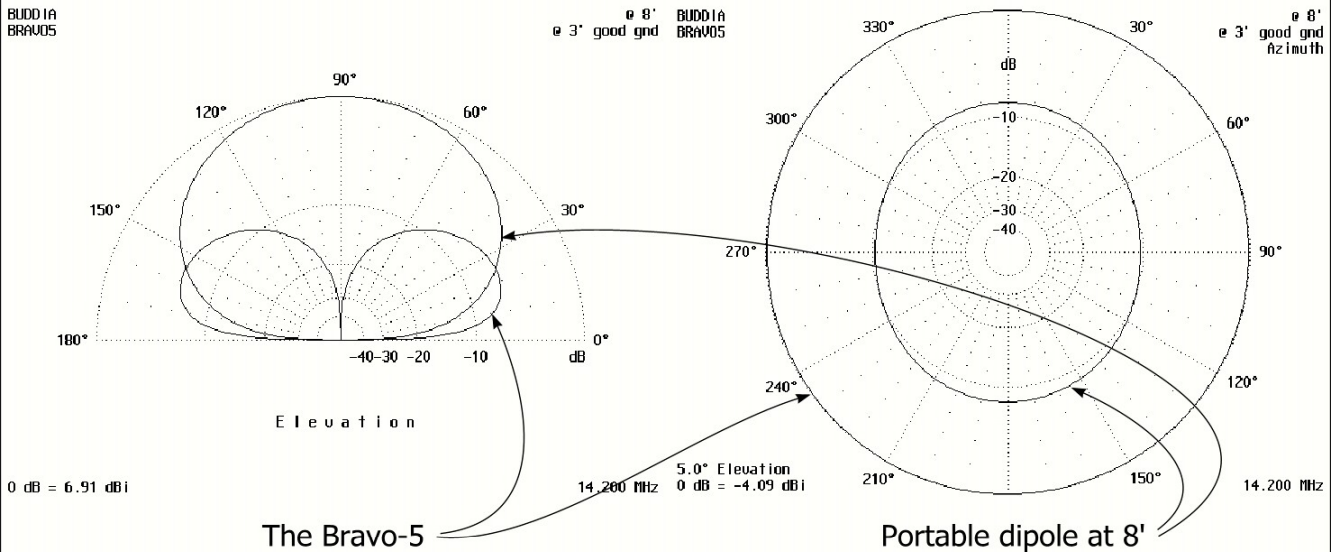

The Bravo-5 is way ahead. The right-hand plot is energy at 5 degrees.

Comparison of Bravo-5 on 20 meters to popular, portable short dipole at 20', 12' higher than its provided mast height of 8'

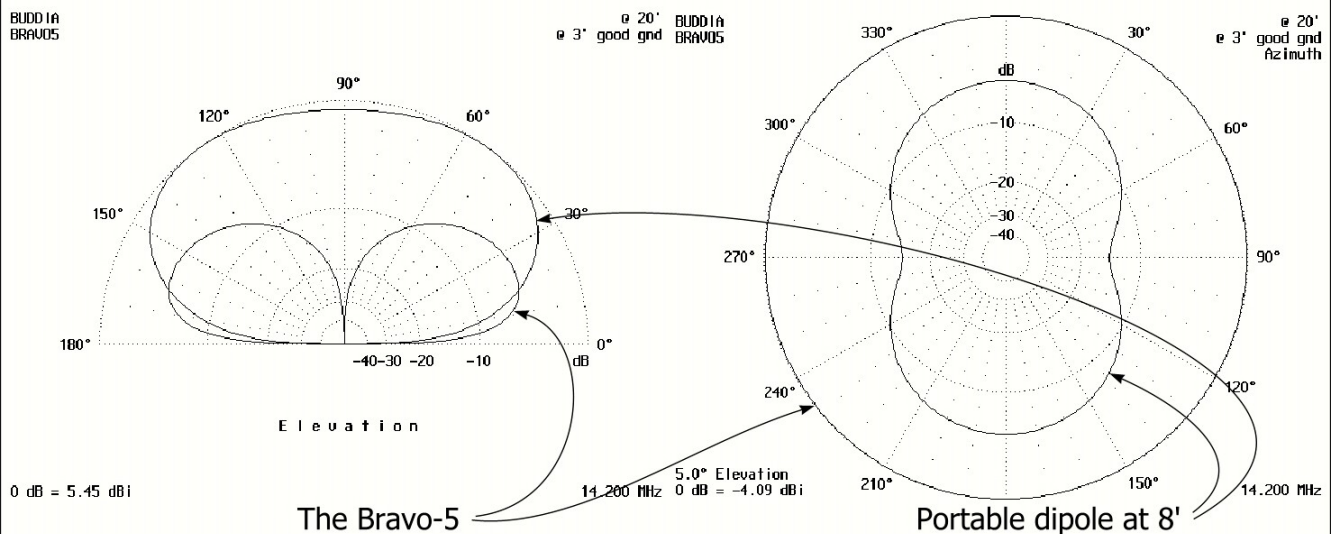

The Bravo-5 is still ahead. The right-hand plot is energy at 5 degrees.

n6bt-bravo-5-d9-rev1.1
Copyright, T.H. Schiller, N6BT 2010
No duplication of design or paperwork is authorized without written statement by T.H. Schiller, N6BT



Bravo 5

5-band vertical dipole, relay switched
Covers the amateur 20-17-15-12-10 meter bands

BRAV05P
BRAV05

e 3' poor gnd BRAV05P
e 3' good gnd BRAV05

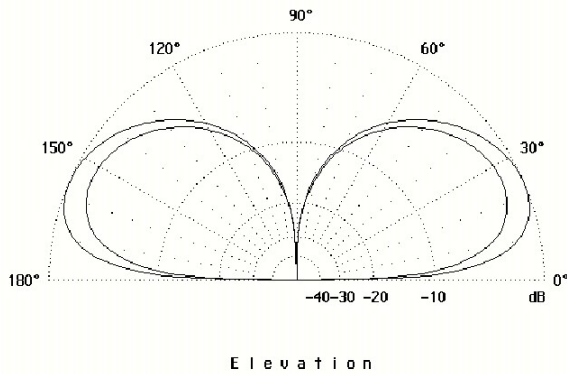

0 dB = .77 dBi

5.0° Elevation
0 dB = -4.09 dBi
14.200 MHz

Elevation comparison of Bravo-5 over poor ground and good ground = +3dB

e 3' poor gnd
e 3' good gnd
Azimuth

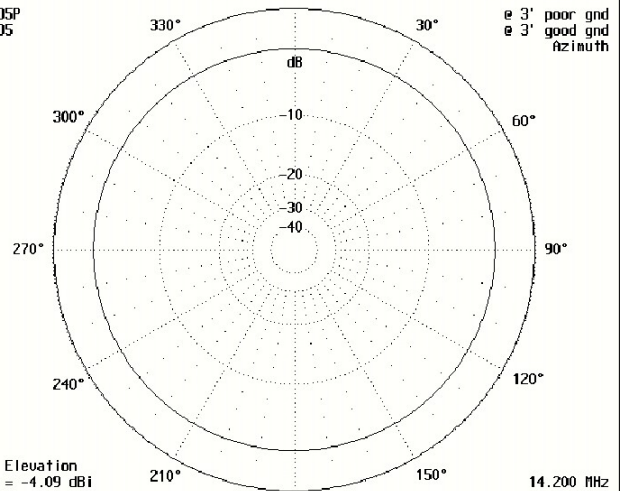

14.200 MHz

Azimuth comparison of Bravo-5 over poor ground and good ground = +3dB

BRAV05P
BRAV05S

e 3' poor gnd BRAV05P
e 3' salt BRAV05S

e 3' good gnd
e 3' salt

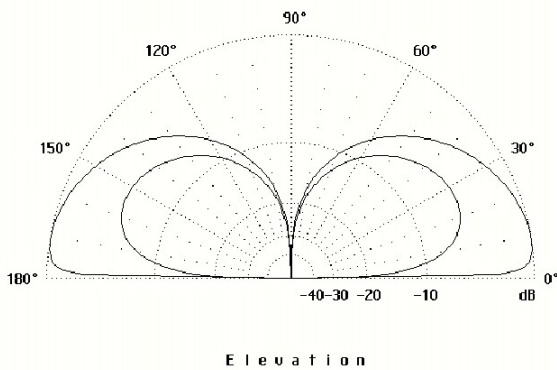

0 dB = 4.26 dBi

14.200 MHz

Comparison of Bravo-5 over poor ground and salt water = +12dB @ 5 degs

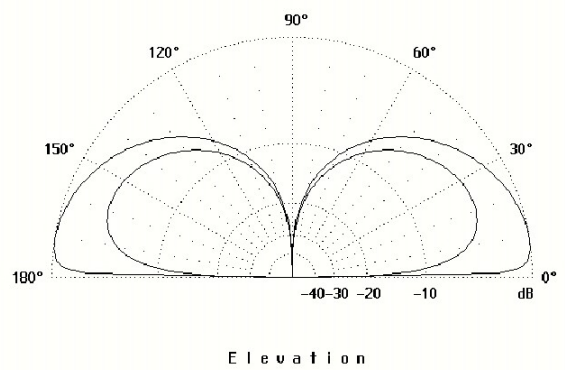

14.200 MHz

Comparison of Bravo-5 over good ground and salt water = +8dB at 5 degs

n6bt-bravo-5-d10-rev1.0
Copyright, T.H. Schiller, N6BT 2010
No duplication of design or paperwork is authorized
without written statement by T.H. Schiller, N6BT



High Voltage Points on Antennas

The voltage present on antennas can be extremely high and is a personal and property danger. Even at low power levels, this voltage can cause severe burns and ignite wood. Be extremely careful.

Shortened, loaded antennas have similar high voltage points.

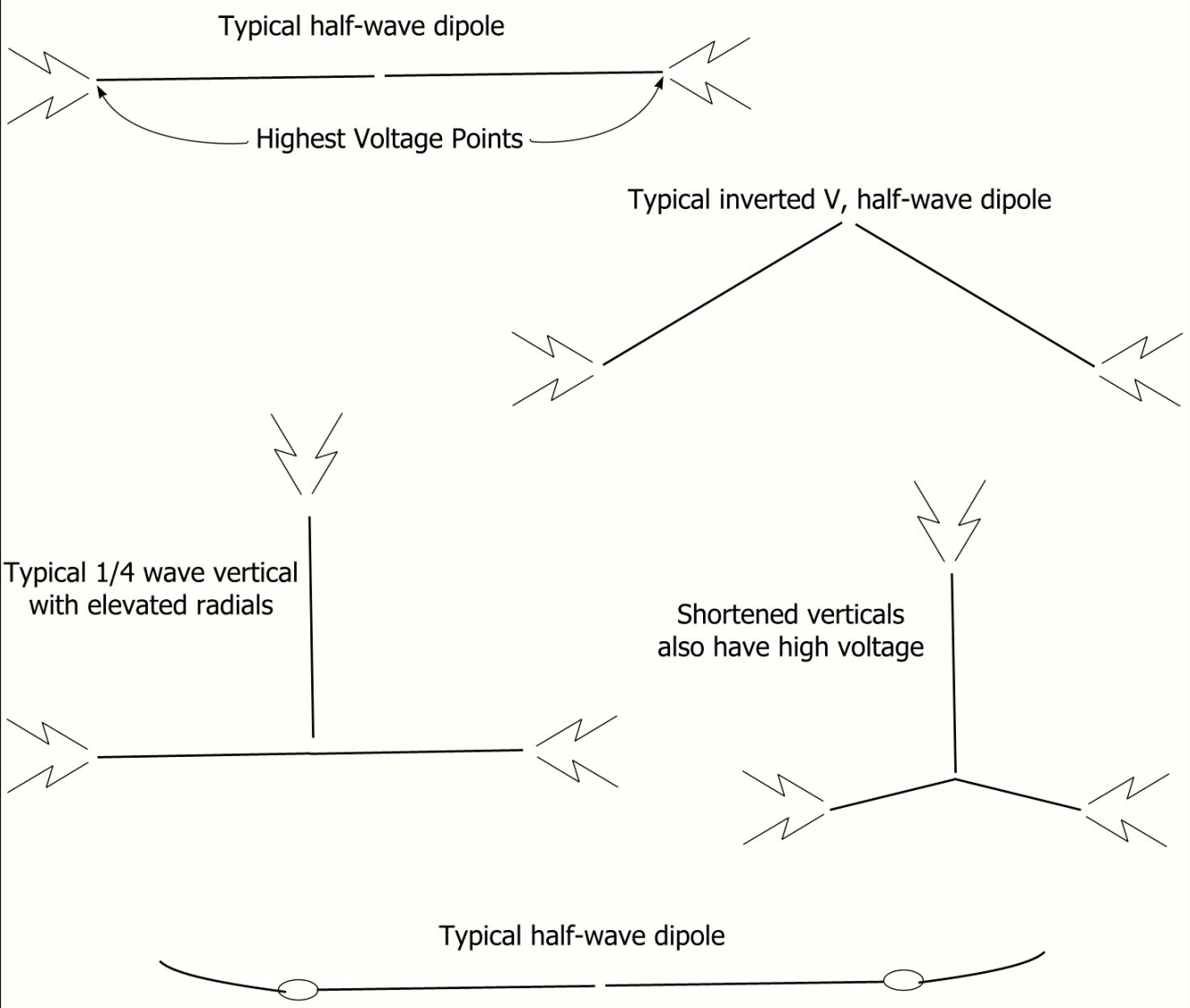

When installing a dipole, especially in an attic, be sure to use end insulators. Large tie-wraps work well. The same goes for using wire for radials on verticals.

n6bt-bravo-5-hv01-rev1.0
Copyright, T.H. Schiller, N6BT 2010
No duplication of design or paperwork is authorized without written statement by T.H. Schiller, N6BT

Last page for notes.....

www.n6bt.com online copy